



EMC TEST REPORT

Certificate No. : TBC-C-202506-0230-4
Report No. : TBR-C-202506-0230-12
Applicant : Zhejiang Lingzhu Technology Co., Ltd.
Equipment Under Test (EUT)
EUT Name : Baby Monitor
Model No. : SC374-WBD3-RX
Series Model No. : SC374-WBD2-RX, SC374-WBD4-RX, SC374-WBD5-RX, SC374-WBD8-RX
Brand Name : ----
Receipt Date : 2025-07-11
Test Date : 2025-07-11 to 2025-08-26
Issue Date : 2025-08-29
Standards : EN 55032:2015+A1:2020
EN IEC 61000-3-2:2019+A2:2024
EN 61000-3-3:2013+A2:2021
EN 55035:2017+A11:2020
Conclusions : **PASS**

In the configuration tested, the EUT complied with the standards specified above. The EUT technically complies with the Council Directive 2014/53/EU relating to radio equipment.

Tested By : *David Yuan*
Reviewed By : *Wade Lv*
Approved By : *IVAN SU*



This report details the results of the testing carried out on one sample. The results contained in this test report do not relate to other samples of the same product. The manufacturer should ensure that all products in series production are in conformity with the product sample detailed in the report.

TABLE OF CONTENTS

1	GENERAL INFORMATION	6
	1.1 Client Information.....	6
	1.2 General Description of EUT (Equipment Under Test).....	6
	1.3 Block Diagram Showing the Configuration of System Tested.....	7
	1.4 Description of Support Units.....	7
	1.5 Description of Operating Mode.....	7
	1.6 Performance Criteria.....	8
	1.7 Measurement Uncertainty.....	9
	1.8 Test Facility.....	9
2	TEST RESULTS SUMMARY	10
3	TEST SOFTWARE	12
4	TEST EQUIPMENT AND TEST SITE	13
5	CONDUCTED DISTURBANCE TEST (AC PORT)	15
	5.1 Test Standard and Limit.....	15
	5.2 Test Setup.....	15
	5.3 Test Procedure.....	16
	5.4 Deviation From Test Standard.....	16
	5.5 Test Data.....	16
6	CONDUCTED EMISSIONS (WIRED NETWORK PORT)	17
	6.1 Test Standard and Limit.....	17
	6.2 Test Setup.....	18
	6.3 Test Procedure.....	19
	6.4 Deviation From Test Standard.....	19
	6.5 Test Data.....	19
7	CONDUCTED DIFFERENTIAL VOLTAGE EMISSIONS	20
	7.1 Test Standard and Limit.....	20
	7.2 Test Setup.....	20
	7.3 Test Procedure.....	21
	7.4 Deviation From Test Standard.....	21
	7.5 Test Data.....	21
8	RADIATED EMISSION TEST	22
	8.1 Test Standard and Limit.....	22
	8.2 Test Setup.....	23
	8.3 Test Procedure.....	24
	8.4 Deviation From Test Standard.....	24
	8.5 Test Data.....	24
9	HARMONIC CURRENT EMISSION TEST	25
	9.1 Test Standard and Limit.....	25
	9.2 Test Setup.....	25
	9.3 Test Procedure.....	25
	9.4 Deviation From Test Standard.....	25
	9.5 Test Data.....	25
10	VOLTAGE FLUCTUATION AND FLICKER TEST	26
	10.1 Test Standard and Limit.....	26
	10.2 Test Setup.....	26
	10.3 Test Procedure.....	26
	10.4 Deviation From Test Standard.....	26



	10.5 Test Data.....	26
11	ELECTROSTATIC DISCHARGE IMMUNITY TEST	27
	11.1 Test Standard and Limit	27
	11.2 Test Setup.....	27
	11.3 Test Procedure.....	27
	11.4 Deviation From Test Standard.....	27
	11.5 Test Data.....	27
12	RADIATED ELECTROMAGNETIC FIELD IMMUNITY TEST	28
	12.1 Test Standard and Limit	28
	12.2 Test Setup.....	28
	12.3 Test Procedure.....	29
	12.4 Deviation From Test Standard.....	29
	12.5 Test Data.....	29
13	ELECTRICAL FAST TRANSIENT/BURST TEST	30
	13.1 Test Standard and Limit	30
	13.2 Test Setup.....	30
	13.3 Test Procedure.....	30
	13.4 Deviation From Test Standard.....	30
	12.5 Test Data.....	30
14	SURGE IMMUNITY TEST	31
	14.1 Test Standard and Limit	31
	14.2 Test Setup.....	31
	14.3 Test Procedure.....	31
	14.4 Deviation From Test Standard.....	31
	14.5 Test Data.....	31
15	RF COMMON MODE.....	32
	15.1 Test Standard and Limit	32
	15.2 Test Setup.....	32
	15.3 Test Procedure.....	32
	15.4 Deviation From Test Standard.....	33
	15.5 Test Data.....	33
16	POWER FREQUENCY MAGNETIC FIELD IMMUNITY TEST	34
	16.1 Test Standard and Limit	34
	16.2 Test Setup.....	34
	16.3 Test Procedure.....	34
	16.4 Deviation From Test Standard.....	34
	16.5 Test Data.....	34
17	VOLTAGE DIPS AND INTERRUPTIONS IMMUNITY TEST	35
	17.1 Test Standard and Limit	35
	17.2 Test Setup.....	35
	17.3 Test Procedure.....	35
	17.4 Deviation From Test Standard.....	35
	17.5 Test Data.....	35
18	PHOTOGRAPHS--CONSTRUCTIONAL DETAILS	36
19	PHOTOGRAPHS--TEST SETUP	43
	ATTACHMENT A--CONDUCTED EMISSION DATA (AC MAINS)	47
	ATTACHMENT B--RADIATED EMISSION TEST DATA	49
	ATTACHMENT C--ELECTROSTATIC DISCHARGE TEST DATA	53
	ATTACHMENT D--RF FIELD STRENGTH SUSCEPTIBILITY TEST DATA.....	55



ATTACHMENT E--ELECTRICAL FAST TRANSIENT/BURST TEST DATA.....	56
ATTACHMENT F--SURGE IMMUNITY TEST DATA.....	57
ATTACHMENT G--CONDUCTED IMMUNITY TEST DATA.....	58
ATTACHMENT H--VOLTAGE DIPS AND INTERRUPTIONS TEST DATA.....	59



1 General Information

1.1 Client Information

Applicant	:	Zhejiang Lingzhu Technology Co., Ltd.
Address	:	Room 302, No 1 Building Huace Center, Xihu District, Hangzhou, China
Manufacturer	:	Zhejiang Lingzhu Technology Co., Ltd.
Address	:	Room 302, No 1 Building Huace Center, Xihu District, Hangzhou, China

1.2 General Description of EUT (Equipment Under Test)

EUT Name	:	Baby Monitor
Model(s)	:	SC374-WBD3-RX, SC374-WBD2-RX, SC374-WBD4-RX, SC374-WBD5-RX, SC374-WBD8-RX
Model Difference	:	All these models are identical in the same PCB layout and electrical circuit, only difference is Appearance color and Model name.
Class of EUT	:	<input type="checkbox"/> Class A <input checked="" type="checkbox"/> Class B
EUT Type	:	<input checked="" type="checkbox"/> Table top <input type="checkbox"/> Floor standing <input type="checkbox"/> combination
Fx	:	2.4GHz
Power Rating	:	Adapter(DCT10W050150EU-C1) Input: 100-240V~50/60Hz 0.3A Output: 5.0V/1.5A 7.5W DC 3.7V 5000mAh 18.5Wh Rechargeable Li-ion battery
Software Version	:	V0.8.6
Hardware Version	:	XHX-RX-V2
Remark	:	----
<p>Remark: Fx: Highest fundamental frequency generated or used within the EUT or highest frequency at which it operates. Class A Equipment: the Equipment is not intended primarily for use in a residential environment. Class B Equipment: the Equipment is intended primarily for use in a residential environment.</p>		



1.3 Block Diagram Showing the Configuration of System Tested

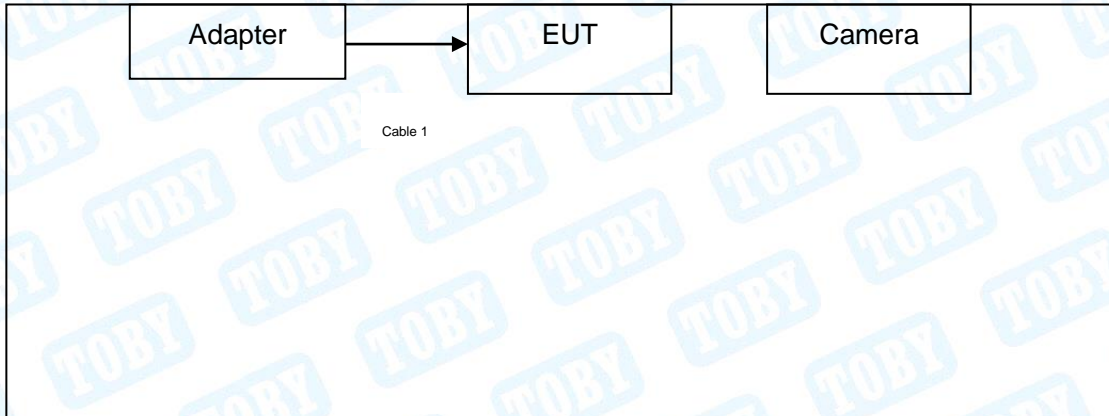

1.4 Description of Support Units

Equipment Information				
Name	Model	S/N	Manufacturer	Used “√”
----	----	----	----	----
Cable Information				
Number	Shielded Type	Ferrite Core	Length	Note
----	----	----	----	----

1.5 Description of Operating Mode

To investigate the maximum EMI emission characteristics generated from EUT, the test system was pre-scanning tested based on the consideration of following EUT operation mode or test configuration mode which possible have effect on EMI emission level. Each of these EUT operation mode(s) or test configuration mode(s) mentioned above was evaluated respectively.

Pretest Mode	Description
Mode 1	Adapter + Monitor Mode

The EUT system operated these modes were found to be the worst case during the pre-scanning test as Following:

For EMI Test	
Final Test Mode	Description
Mode 1	Adapter + Monitor Mode
For EMS Test	
Final Test Mode	Description
Mode 1	Adapter + Monitor Mode



1.6 Performance Criteria

General

General performance criteria are defined in 8.2, 8.3 and 8.4. These criteria shall be used during the testing of primary functions where no relevant annex is applicable.

When assessing the impact of a disturbance on a function, the assessment should take into consideration the function's performance prior to the application of the disturbance and only identify as failures those changes in performance that are a result of the disturbance.

Performance criterion A

The equipment shall continue to operate as intended without operator intervention. No degradation of performance, loss of function or change of operating state is allowed below a performance level specified by the manufacturer when the equipment is used as intended. The performance level may be replaced by a permissible loss of performance. If the minimum performance level or the permissible performance loss is not specified by the manufacturer, then either of these may be derived from the product description and documentation, and by what the user may reasonably expect from the equipment if used as intended.

Performance criterion B

During the application of the disturbance, degradation of performance is allowed. However, no unintended change of actual operating state or stored data is allowed to persist after the test.

After the test, the equipment shall continue to operate as intended without operator intervention; no degradation of performance or loss of function is allowed, below a performance level specified by the manufacturer, when the equipment is used as intended. The performance level may be replaced by a permissible loss of performance.

If the minimum performance level (or the permissible performance loss), or recovery time, is not specified by the manufacturer, then either of these may be derived from the product description and documentation, and by what the user may reasonably expect from the equipment if used as intended.

Performance criterion C

Loss of function is allowed, provided the function is self-recoverable, or can be restored by the operation of the controls by the user in accordance with the manufacturer's instructions. A reboot or re-start operation is allowed.

Information stored in non-volatile memory, or protected by a battery backup, shall not be lost.



1.7 Measurement Uncertainty

The reported uncertainty of measurement $y \pm U$, where expanded uncertainty U is based on a standard uncertainty multiplied by a coverage factor of $k=2$, providing a level of confidence of approximately 95 %.

Test Item	Expanded Uncertainty (U_{Lab})
Conducted Emission	± 3.50 dB
Radiated Emission (9kHz to 30 MHz)	± 4.60 dB
Radiated Emission (30MHz to 1000 MHz)	± 4.60 dB
Radiated Emission (Above 1000MHz)	± 4.50 dB
Temperature	$\pm 0.6^{\circ}\text{C}$
Humidity	$\pm 4\%$

1.8 Test Facility

The testing report were performed by the Shenzhen Toby Technology Co., Ltd., in their facilities located at 1/F., Building 6, Rundongsheng Industrial Zone, Longzhu, Xixiang, Bao'an District, Shenzhen, Guangdong, China. At the time of testing, the following bodies accredited the Laboratory:

CNAS (L5813)

The Laboratory has been accredited by CNAS to ISO/IEC 17025: 2017 General Requirements for the Competence of Testing and Calibration Laboratories for the competence in the field of testing. And the Registration No.: CNAS L5813.

A2LA Certificate No.: 4750.01

The laboratory has been accredited by American Association for Laboratory Accreditation(A2LA) to ISO/IEC 17025: 2017 General Requirements for the Competence of Testing and Calibration Laboratories for the technical competence in the field of Electrical Testing. And the A2LA Certificate No.: 4750.01.FCC Accredited Test Site Number: 854351.Designation Number: CN1223.

IC Registration No.: (11950A)

The Laboratory has been registered by Certification and Engineering Bureau of Industry Canada for radio equipment testing. The site registration: Site# 11950A. CAB identifier: CN0056.



2 Test Results Summary

EMISSION (<input checked="" type="checkbox"/> EN 55032:2015+A1:2020)			
Description of test items	Standards	Class	Results
Conducted disturbance at mains terminals	EN 55032:2015+A1:2020	<input type="checkbox"/> Class A	Pass ⁽¹⁾
		<input checked="" type="checkbox"/> Class B	
Conducted disturbance for asymmetric mode	EN 55032:2015+A1:2020	<input type="checkbox"/> Class A	N/A
		<input checked="" type="checkbox"/> Class B	
Conducted differential voltage emission	EN 55032:2015+A1:2020	Class B	N/A ⁽²⁾
Radiated Disturbance	EN 55032:2015+A1:2020	<input type="checkbox"/> Class A	Pass
		<input checked="" type="checkbox"/> Class B	
Harmonic current emissions	EN IEC 61000-3-2:2019+A1:2021+A2:2024	<input checked="" type="checkbox"/> Class A	N/A ⁽⁵⁾
		<input type="checkbox"/> Class D	
Voltage fluctuation and flicker	EN 61000-3-3:2013+A2:2021		N/A
<p>Note:</p> <p>(1) Class A/Class B: Applicable to AC mains power ports</p> <p>(2) Class A: Applicable to wired network ports, optical fibre ports with metallic shield or tension members and antenna ports. Class B: Applicable to wired network ports, optical fibre ports with metallic shield or tension members, broadcast receiver tuner ports and antenna ports. Applicable to ports listed above and intended to connect to cables longer than 3 m.</p> <p>(3) Class B: Applicable to TV broadcast receiver tuner ports with an accessible connector, RF modulator output ports and FM broadcast receiver tuner ports with an accessible connector.</p> <p>(4) Class A: Balanced three-phase equipment, Household appliances excluding equipment as Class D, Tools excluding portable tools, Dimmers for incandescent lamps, audio equipment, equipment not specified in one of the three other classes. Class D: Equipment having a specified power less than or equal to 600 W of the following types: Personal computers and personal computer monitors and television receivers.</p> <p>(5) The power consumption of EUT is less than 75W and no Limits apply.</p>			



IMMUNITY (<input checked="" type="checkbox"/> EN 55035:2017+A11:2020)		
Description of test items	Standards	Results
Electrostatic Discharge (ESD)	EN 61000-4-2:2009	Pass
Continuous RF Electromagnetic Field Disturbances	EN IEC 61000-4-3:2020	Pass
EFT/B Immunity	EN 61000-4-4:2012	Pass
Surge Immunity	EN 61000-4-5:2014+A1:2017	Pass
Continuous RF Disturbances	EN 61000-4-6:2014	Pass
Power frequency magnetic field	EN 61000-4-8:2010	N/A
Voltage dips	EN IEC 61000-4-11:2020	Pass
Voltage interruptions		
Note: (1) N/A is an abbreviation for Not Applicable.		
Monitoring EUT in Immunity Test: At the start of the test, establish a wireless link between the Transmitter and receiver and check EUT operate as intended; During the test, observe the EUT working performance by monitor or by the eyes; After the test, Check the function of the EUT with no degradation.		



3 Test Software

Test Item	Test Software	Manufacturer	Version No.
Conducted Emission	EZ-EMC	EZ	CDI-03A2
Radiation Emission	EZ-EMC	EZ	FA-03A2RE
Radiation Emission	EZ-EMC	EZ	FA-03A2RE+
Radiation Immunity	TS+(J32-RS)	Tonsced	3.0.0.5
Harmonic Current	CTS4	CI	4.24.0
Voltage Fluctuation and Flicker	CTS4	CI	4.24.0
Conducted Immunity	IEC/EN 61000-6-4 Application	FRANKONIA	1.1.1
Electrical Fast Transient	lec.control	Nemtest	5.1.1.0
Surge	lec.control	Nemtest	5.1.1.0
Voltage Dip and Interruption	lec.control	Nemtest	5.1.1.0



4 Test Equipment and Test Site

Test Site				
No.	Test Site	Manufacturer	Specification	Used
TB-EMCSR001	Shielding Chamber #1	YIHENG	7.5*4.0*3.0 (m)	√
TB-EMCSR002	Shielding Chamber #2	YIHENG	8.0*4.0*3.0 (m)	X
TB-EMCCA001	3m Anechoic Chamber #A	ETS	9.0*6.0*6.0 (m)	X
TB-EMCCB002	3m Anechoic Chamber #B	YIHENG	9.0*6.0*6.0 (m)	√

Conducted Emission Test					
Equipment	Manufacturer	Model No.	Serial No.	Last Cal.	Cal. Due Date
EMI Test Receiver	Rohde & Schwarz	ESCI	100321	Jun. 16, 2025	Jun. 15, 2026
RF Switching Unit	Compliance Direction Systems Inc	RSU-A4	34403	Jun. 16, 2025	Jun. 15, 2026
AMN	SCHWARZBECK	NNBL 8226-2	8226-2/164	Jun. 16, 2025	Jun. 15, 2026
LISN	Rohde & Schwarz	ENV216	101131	Jun. 16, 2025	Jun. 15, 2026
Radiation Emission Test (B Site)					
Equipment	Manufacturer	Model No.	Serial No.	Last Cal.	Cal. Due Date
Spectrum Analyzer	Agilent	N9020A	MY49100060	Aug. 29, 2024	Aug. 28, 2025
Spectrum Analyzer	Rohde & Schwarz	FSV40-N	102197	Jun. 16, 2025	Jun. 15, 2026
EMI Test Receiver	Rohde & Schwarz	ESU-8	100472/008	Feb. 20, 2025	Feb. 19, 2026
Bilog Antenna	SCHWARZBECK	VULB 9168	1225	Nov. 13, 2023	Nov. 12, 2025
Horn Antenna	SCHWARZBECK	BBHA 9120 D	2463	Jun. 14, 2024	Jun. 13, 2026
Horn Antenna	SCHWARZBECK	BBHA 9170	1118	Feb. 27, 2024	Feb. 26, 2026
Loop Antenna	SCHWARZBECK	FMZB 1519 B	1519B-059	Jun. 14, 2024	Jun. 13, 2026
HF Amplifier	Tonscend	TAP9E6343	AP21C806117	Aug. 29, 2024	Aug. 28, 2025
HF Amplifier	Tonscend	TAP051845	AP21C806141	Aug. 29, 2024	Aug. 28, 2025
HF Amplifier	Tonscend	TAP0184050	AP21C806129	Aug. 29, 2024	Aug. 28, 2025
Harmonic Current and Voltage Fluctuation and Flicker Test					
Equipment	Manufacturer	Model No.	Serial No.	Last Cal.	Cal. Due Date
Harmonic Flicker Test System	CI	5001ix-CTS-400	100321	Jun. 16, 2025	Jun. 15, 2026
AC Power Source	CI	500liX	59468	Jun. 16, 2025	Jun. 15, 2026
Discharge Immunity Test					
Equipment	Manufacturer	Model No.	Serial No.	Last Cal.	Cal. Due Date
ESD Tester	TESEQ	NSG437	304	Jun. 18, 2025	Jun. 17, 2026



Radiated Immunity Test					
Equipment	Manufacturer	Model No.	Serial No.	Last Cal.	Cal. Due Date
Gestockte Log.-Per.-Breitband-antenna Stacked Log.-Per.-Broadband	SCHWARZBECK	STLP 9129	162	N/A	N/A
Electric field probe	Narda	EP 601	811ZX01000	Feb. 21, 2025	Feb. 20, 2026
Signal Generator	Agilent	N5181A	MY50141953	Aug. 29, 2024	Aug. 28, 2025
EPM Series Power Meter	KEYSIGHT	N1914A	MY61180020	Jun. 16, 2025	Jun. 15, 2026
Power Sensor	KEYSIGHT	E9301A	MY61130007	Jun. 16, 2025	Jun. 15, 2026
Power Sensor	KEYSIGHT	E9301A	MY61130011	Jun. 16, 2025	Jun. 15, 2026
Radio Frequency Switch	Tonscend	JS0806s	21E8060428	N/A	N/A
Microwave Power amplifier	Micotop	MPA-80-1000-250	MPA2105144	Jun. 16, 2025	Jun. 15, 2026
Microwave Power amplifier	Micotop	MPA-1000-6000-100	MPA2105150	Jun. 16, 2025	Jun. 15, 2026
Electrical Fast Transient/ Surge/ Voltage Dip and Interruption Test					
Equipment	Manufacturer	Model No.	Serial No.	Last Cal.	Cal. Due Date
Simulator	EMTEST	UCS500N5	V0948105575	Jun. 16, 2025	Jun. 15, 2026
Auto-transformer	EMTEST	V4780S2	0109-41	Jun. 16, 2025	Jun. 15, 2026
Coupling Clamp	EMTEST	HFK	1109-04	Jun. 16, 2025	Jun. 15, 2026
Combined wave surge simulator	3ctest	1000CM	ES058001920002	Aug. 29, 2024	Aug. 28, 2025
Combined wave surge simulator	3ctest	1000MM	ES058002020002	Aug. 29, 2024	Aug. 28, 2025
External 10KV single-phase coupling /decoupling network	3ctest	SPN2216S10	ES071002020001	Aug. 29, 2024	Aug. 28, 2025
CDN	3ctest	CDN405T8A1	ES2731916	Aug. 29, 2024	Aug. 28, 2025
CDN	3ctest	CDN405AF8	ES064000220008	Aug. 29, 2024	Aug. 28, 2025
Conducted Immunity Test					
Equipment	Manufacturer	Model No.	Serial No.	Last Cal.	Cal. Due Date
RF Generator	FRANKONIA	CIT-10/75	126B1126	Jun. 16, 2025	Jun. 15, 2026
Attenuator	FRANKONIA	59-6-33	A413	Jun. 16, 2025	Jun. 15, 2026
M-CDN	LUTHI	L-801 M2/M3	2599	Jun. 16, 2025	Jun. 15, 2026
AF2-CDN	LUTHI	L-801:AF2	2538	Feb. 20, 2025	Feb. 19, 2026
EM Injection Clamp	LUTHI	EM101	35958	Jun. 16, 2025	Jun. 15, 2026



5 Conducted Disturbance Test (AC Port)

5.1 Test Standard and Limit

5.1.1 Test Standard

EN 55032:2015+A1:2020

5.1.2 Test Limit

Table A.9 – Requirements for conducted emissions from the AC mains power ports of Class A equipment

Applicable to				
1. AC mains power ports (3.1.1)				
Table clause	Frequency range MHz	Coupling device (see Table A.8)	Detector type / bandwidth	Class A limits dB(μ V)
A9.1	0,15 to 0,5	AMN	Quasi Peak / 9 kHz	79
	0,5 to 30			73
A9.2	0,15 to 0,5	AMN	Average / 9 kHz	66
	0,5 to 30			60

Apply A9.1 and A9.2 across the entire frequency range.

Table A.10 – Requirements for conducted emissions from the AC mains power ports of Class B equipment

Applicable to				
1. AC mains power ports (3.1.1)				
Table clause	Frequency range MHz	Coupling device (see Table A.8)	Detector type / bandwidth	Class B limits dB(μ V)
A10.1	0,15 to 0,5	AMN	Quasi Peak / 9 kHz	66 to 56
	0,5 to 5			56
	5 to 30			60
A10.2	0,15 to 0,5	AMN	Average / 9 kHz	56 to 46
	0,5 to 5			46
	5 to 30			50

Apply A10.1 and A10.2 across the entire frequency range.

5.2 Test Setup

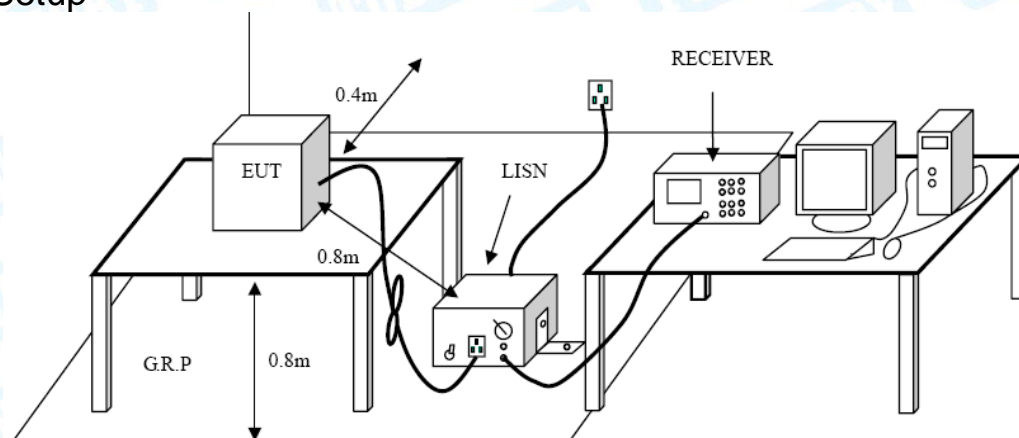

5.3 Test Procedure

The EUT was placed 0.8 meters from the horizontal ground plane with EUT being connected to the power mains through a line impedance stabilization network (LISN). All other support equipments powered from additional LISN(s). The LISN provide 50 Ohm/50uH of coupling impedance for the measuring instrument.

Interconnecting cables that hang closer than 40 cm to the ground plane shall be folded back and forth in the center forming a bundle 30 to 40 cm long.

I/O cables that are not connected to a peripheral shall be bundled in the center. The end of the cable may be terminated, if required, using the correct terminating impedance. The overall length shall not exceed 1 m.

LISN at least 80 cm from the nearest part of EUT chassis.

The bandwidth of EMI test receiver is set at 9kHz, and the test frequency band is from 0.15MHz to 30MHz.

5.4 Deviation From Test Standard

No deviation

5.5 Test Data

Please refer to the Attachment A.



6 Conducted Emissions (Wired Network Port)

6.1 Test Standard and Limit

6.1.1 Test Standard

EN 55032:2015+A1:2020

6.1.2 Test Limit

Table A.11 – Requirements for asymmetric mode conducted emissions from Class A equipment

Applicable to					
1. wired network ports (3.1.32) 2. optical fibre ports (3.1.25) with metallic shield or tension members 3. antenna ports (3.1.3)					
Table clause	Frequency range MHz	Coupling device (see Table A.8)	Detector type / bandwidth	Class A voltage limits dB(μV)	Class A current limits dB(μA)
A11.1	0,15 to 0,5	AAN	Quasi Peak / 9 kHz	97 to 87	n/a
	0,5 to 30			87	
	0,15 to 0,5	AAN	Average / 9 kHz	84 to 74	
	0,5 to 30			74	
A11.2	0,15 to 0,5	CVP and current probe	Quasi Peak / 9 kHz	97 to 87	53 to 43
	0,5 to 30			87	43
	0,15 to 0,5	CVP and current probe	Average / 9 kHz	84 to 74	40 to 30
	0,5 to 30			74	30
A11.3	0,15 to 0,5	Current Probe	Quasi Peak / 9 kHz	n/a	53 to 43
	0,5 to 30				43
	0,15 to 0,5	Current Probe	Average / 9 kHz		40 to 30
	0,5 to 30				30
The choice of coupling device and measurement procedure is defined in Annex C. AC mains ports that also have the function of a wired network port shall meet the limits given in Table A.9. The measurement shall cover the entire frequency range. The application of the voltage and/or current limits is dependent on the measurement procedure used. Refer to Table C.1 for applicability. Testing is required at only one EUT supply voltage and frequency. Applicable to ports listed above and intended to connect to cables longer than 3 m.					



6.3 Test Procedure

Detailed test procedure was following clause C.4.1 of EN 55032.

Frequency range 150kHz–30MHz was checked and EMI receiver measurement bandwidth was set to 9 kHz.

Data Port	Measurement type	Coupling device	No. of Pairs
Balanced Unscreened	Voltage	AAN	≤ 4
Balanced Unscreened	Voltage and Current	CVP & Current probe	>4 or unable to AAN
Screened or Coaxial	Voltage	AAN	N/A
Screened or Coaxial	Voltage or Current	Current probe / "150Ω to 50Ω adaptor" / high impedance probe	N/A
Unbalanced cables	Voltage and Current	CVP & Current probe	N/A

6.4 Deviation From Test Standard

No deviation

6.5 Test Data

N/A.



7 Conducted Differential Voltage Emissions

7.1 Test Standard and Limit

7.1.1 Test Standard

EN 55032:2015+A1:2020

7.1.2 Test Limit

Requirements for Conducted differential voltage emissions from Class B equipment

Applicability	Frequency range (MHz)	Differential voltage limit @ 75Ω (dBuV)		
		Other	Local Oscillator Fundamental	Local Oscillator Harmonics
Television receivers; Digital Video Recorders; PC TV broadcast receiver tuner cards; Digital audio receivers;	30 ~ 950	46	46	46
	950 ~ 2 150	46	54	54
Tuner units (not the LNB) for satellite signal reception	950 ~ 2 150	46	54	54
FM audio receivers and PC tuner cards	30 ~ 300	46	54	50
	300 ~ 1 000	46	54	52
FM car radios	30 ~ 300	46	66	59
	300 ~ 1 000	46	66	52
RF modulator output ports connect to TV broadcast receiver tuner ports	30 ~ 950	46	76	46
	950 ~ 2150	46	/	54

7.2 Test Setup

TV/FM broadcast receiver tuner ports

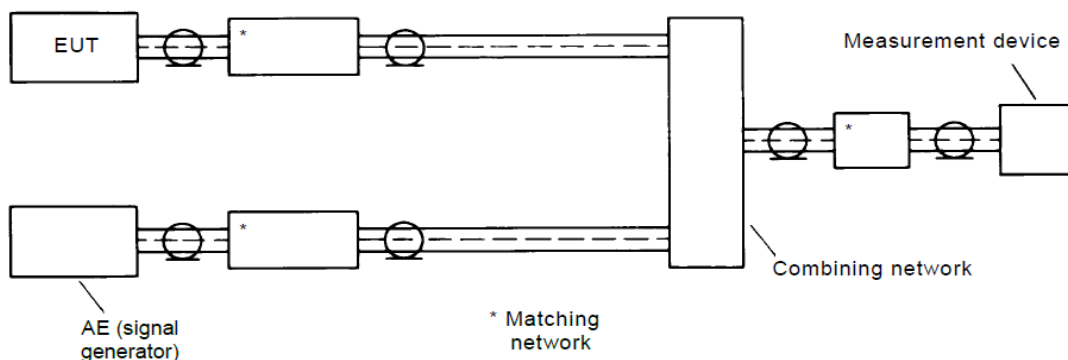

RF modulator output port

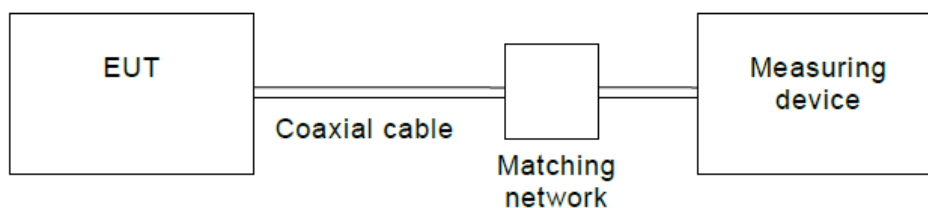

7.3 Test Procedure

Detailed test procedure was following clause C4.2 and C4.3 of EN55032.
Frequency range 30MHz – 2150MHz was checked and EMI receiver measurement bandwidth was set to 120kHz /1MHz.

7.4 Deviation From Test Standard

No deviation

7.5 Test Data

N/A.



8 Radiated Emission Test

8.1 Test Standard and Limit

8.1.1 Test Standard

EN 55032:2015+A1:2020

8.1.2 Test Limit

Radiated Disturbance Test Limit

FREQUENCY (MHz)	Class A (at 3m)	Class B (at 3m)
	dBuV/m	dBuV/m
30 – 230	50	40
230 – 1000	57	47

Notes:

- (1) The limit for radiated test was performed according to as following: EN 55032
- (2) The tighter limit applies at the band edges.
- (3) Emission level (dBuV/m)=20log Emission level (uV/m).

Limits of Radiated Emission Measurement (Above 1000MHz)

FREQUENCY (MHz)	Class A (dBuV/m) (at 3m)		Class B (dBuV/m) (at 3m)	
	PEAK	AVERAGE	PEAK	AVERAGE
1000-3000	80	60	74	54
3000-6000	80	60	74	54

Notes:

- (1) The lower limit applies at the transition frequency.

Frequency Range of Radiated Measurement

Highest frequency generated or Upper frequency of measurement used in the device or on which the device operates or tunes (MHz)	Range (MHz)
Below 108	1000
108 – 500	2000
500 – 1000	5000
Above 1000	5th harmonic of the highest frequency or 6 GHz, whichever is lower



8.2 Test Setup

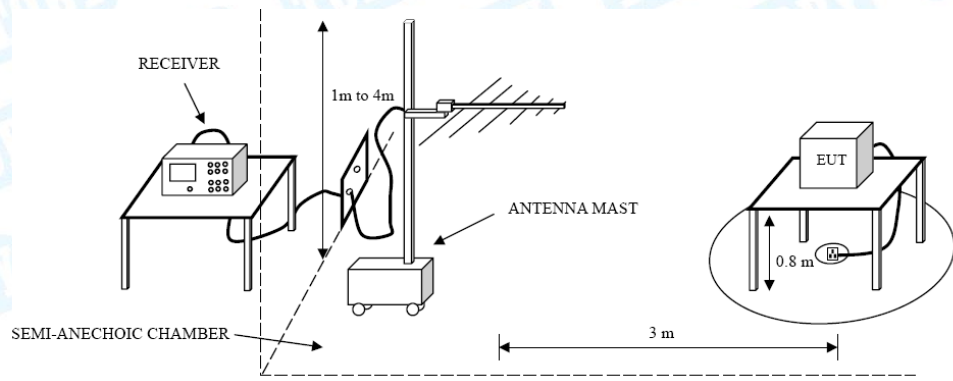

Below-1G

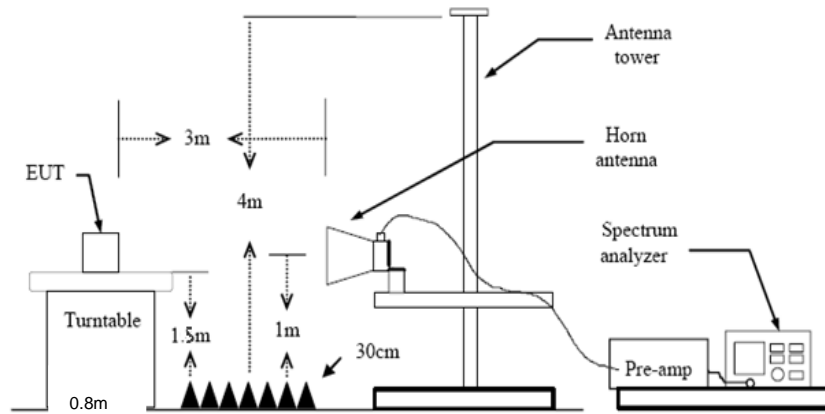

Above 1G

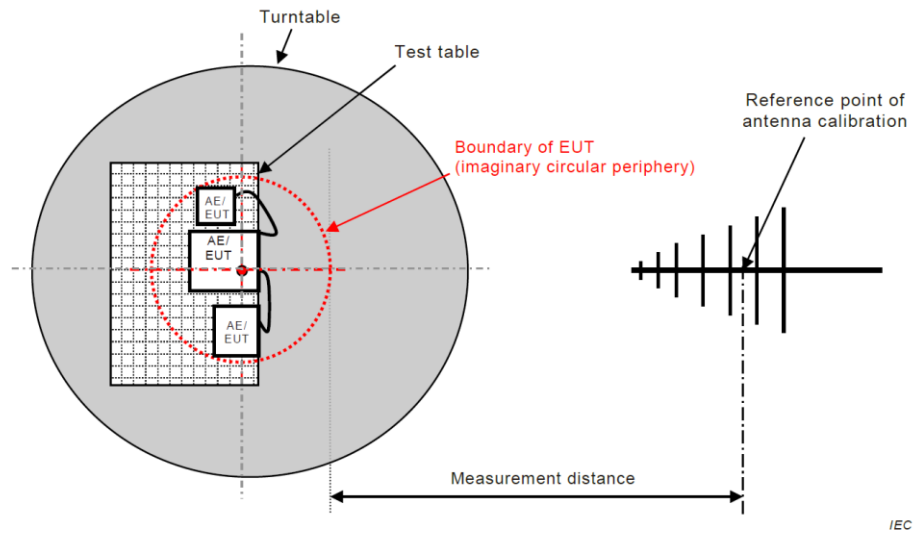

Figure C.1 – Measurement distance



8.3 Test Procedure

The EUT was placed on the top of a rotating table 0.8 meters above the ground at a 3m. The table was rotated 360 degrees to determine the position of the highest radiation.

The EUT and local AE shall be arranged in the most compact practical arrangement within the test volume, while respecting typical spacing and the requirements defined in Annex D. The central point of the arrangement shall be positioned at the centre of the turntable. The measurement distance is the shortest horizontal distance between an imaginary circular periphery just encompassing this arrangement and the calibration point of the antenna. See Figure C.1 and Figure C.2.

The height of the equipment or of the substitution antenna shall be 0.8 m; the height of the test antenna shall vary between 1 m to 4 m. Both horizontal and vertical polarizations of the antenna are set to make the measurement.

The initial step in collecting radiated emission data is a spectrum Quasi Peak detector mode scanning the measurement frequency range.

If the Peak Mode measured value compliance with and lower than Quasi Peak Mode Limit, the EUT shall be deemed to meet QP Limits and then no additional QP Mode measurement performed.

8.4 Deviation From Test Standard

No deviation

8.5 Test Data

Please refer to the Attachment B.



9 Harmonic Current Emission Test

9.1 Test Standard and Limit

9.1.1 Test Standard

EN IEC 61000-3-2:2019+A1:2021+A2:2024

9.1.2 Test Limit

Limits for Class A equipment				Limits for Class D equipment		
Odd Harmonics		Even Harmonics		Harmonic Order (n)	Maximum Permissible Harmonic Current per watt (mA/W)	Maximum Permissible Harmonic Current (A)
Harmonic Order (n)	Maximum permissible harmonic Current (A)	Harmonic Order (n)	Maximum permissible harmonic Current (A)			
3	2.30	2	1.08	3	3.4	2.30
5	1.14	4	0.43	5	1.9	1.14
7	0.77	6	0.30	7	1.0	0.77
9	0.40	8 ≤ n ≤ 40	0.23X8/n	9	0.5	0.40
11	0.33			11	0.35	0.33
13	0.21			15 ≤ n ≤ 39	3.85/n	0.15X15/n
15 ≤ n ≤ 39	0.15X15/n			(odd harmonics only)		

9.2 Test Setup

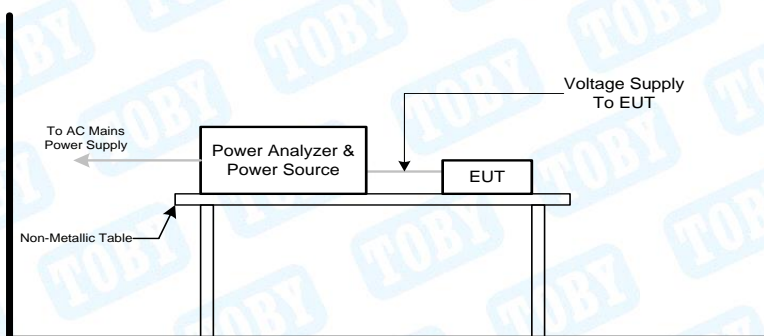

9.3 Test Procedure

The EUT was placed on the top of a wooden table 0.8 meters above the ground and operated to produce the maximum harmonic components under normal operating conditions.

The classification of EUT is according to section 5 of EN 61000-3-2. The EUT is classified as follows:

Class A: Balanced three-phase equipment, Household appliances excluding equipment as Class D, Tools excluding portable tools, Dimmers for incandescent lamps, audio equipment, equipment not specified in one of the three other classes.

Class D: Equipment having a specified power less than or equal to 600 W of the following types: Personal computers and personal computer monitors and television receivers.

9.4 Deviation From Test Standard

No deviation

9.5 Test Data

N/A.



10 Voltage Fluctuation and Flicker Test

10.1 Test Standard and Limit

10.1.1 Test Standard

EN 61000-3-3:2013+A2:2021

10.1.2 Test Limit

Flicker Test Limit

Test Items	Limits
Pst	1.0
dc	3.3%
dmax	4.0%
dt	Not exceed 3.3% for 500ms

10.2 Test Setup

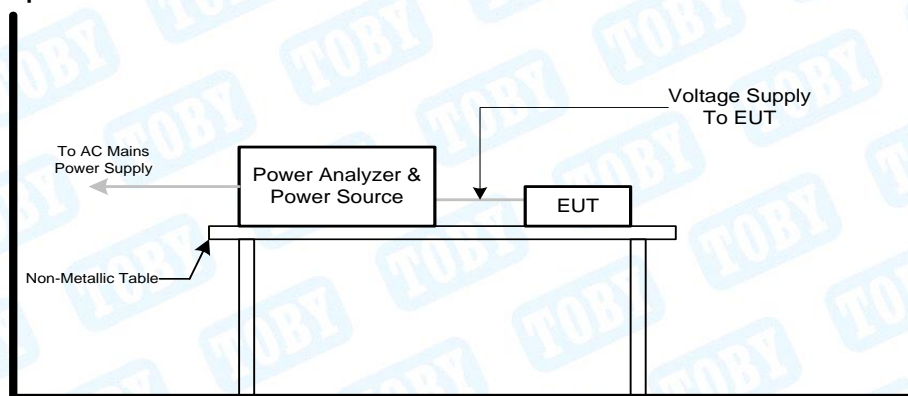

10.3 Test Procedure

Fluctuation and Flickers Test:

Tests was performed according to the Test Conditions/Assessment of Voltage Fluctuations specified in Clause 5.0/6.0 of IEC555-3 and/or Clause 6.0/4.0 of IEC/EN 61000-3-3 depend on which standard adopted for compliance measurement.

All types of harmonic current and/or voltage fluctuation in this report are assessed by direct measurement using flicker-meter.

For the actual test configuration, please refer to the related Item–Block Diagram of system tested.

10.4 Deviation From Test Standard

No deviation

10.5 Test Data

N/A.



11 Electrostatic Discharge Immunity Test

11.1 Test Standard and Limit

11.1.1 Test Standard

EN 55035:2017+A11:2020
EN 61000-4-2:2009

11.1.2 Test Level

Discharge Impedance:	330 ohm/ 150pF
Discharge Voltage:	Air Discharge: 2kV/4kV/8kV(Direct) Contact Discharge: 2kV/4kV (Direct /Indirect)
Polarity:	Positive& Negative
Discharge Mode:	Single Discharge
Discharge Period:	1 second minimum

11.2 Test Setup

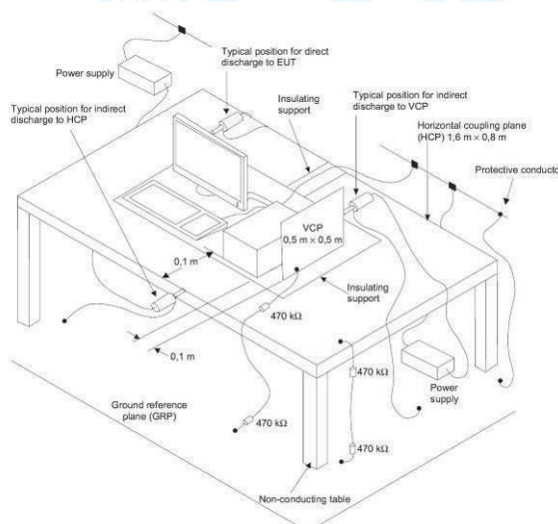

11.3 Test Procedure

The test method shall be in accordance with CENELEC EN 61000-4-2 [2], clauses 6, 7 and 8.

For radio equipment and ancillary equipment the following requirements and evaluation of test results shall apply.

The test severity level for contact discharge shall be ± 4 kV and for air discharge ± 8 kV. All other details, including intermediate test levels, are contained within CENELEC EN 61000-4-2 [2], clause 5.

Electrostatic discharges shall be applied to all exposed surfaces of the EUT except where the user documentation specifically indicates a requirement for appropriate protective measures (as specified in CENELEC EN 61000-4-2 [2], clauses 8.3.2 and 8.3.3).

11.4 Deviation From Test Standard

No deviation

11.5 Test Data

Please refer to the Attachment C.



12 Radiated Electromagnetic Field Immunity test

12.1 Test Standard and Limit

12.1.1 Test Standard

EN 55035:2017+A11:2020

EN IEC 61000-4-3:2020

12.1.2 Test Level

Test Level for Radiated Electromagnetic Field Immunity Test

Port	Test Specification
Enclosure Port	80-1000MHz, 1800MHz, 2600MHz, 3500MHz, 5000MHz 3 V/m 80 % AM (1kHz)

12.2 Test Setup

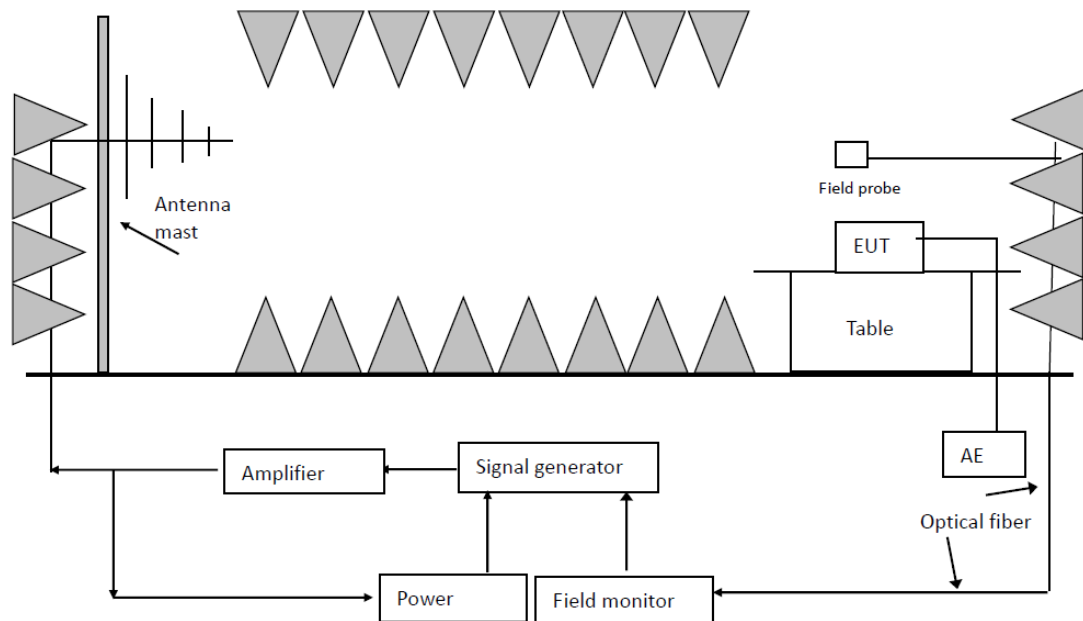

12.3 Test Procedure

The test method shall be in accordance with CENELEC EN 61000-4-3 [3], clauses 6, 7 and 8.

The following requirements and evaluation of test results shall apply:

- the test level shall be 3 V/m (measured unmodulated). The test signal shall be amplitude modulated to a depth of 80 % by a sinusoidal audio signal of 1 000 Hz.

If the wanted signal is modulated at 1 000 Hz, then an audio signal of 400 Hz shall be used;

- the test shall be performed over the frequency range 80 MHz to 6 000 MHz with the exception of the exclusion band for transmitters, receivers and duplex transceivers (see clause 4.3), as appropriate;
- for receivers and transmitters the stepped frequency increments shall be 1 % frequency increment of the momentary used frequency;
- the dwell time of the test phenomena at each frequency shall not be less than the time necessary for the EUT to be exercised and to be able to respond;

NOTE: Dwell time is product dependent.

- the frequencies selected and used during the test shall be recorded.

All the scanning conditions are as following:

Condition of Test	Remark
Fielded Strength	3V/m
Radiated Signal	80%AM,1kHz Since Wave
Scanning Frequency	80-1000MHz, 1800MHz, 2600MHz, 3500MHz, 5000MHz

12.4 Deviation From Test Standard

No deviation

12.5 Test Data

Please refer to the Attachment D.



13 Electrical Fast Transient/Burst Test

13.1 Test Standard and Limit

13.1.1 Test Standard

EN 55035:2017+A11:2020

EN 61000-4-4:2012

13.1.2 Test Level

Test Level for Electrical Fast Transient Test

	On Switching Adapter Lines	On I/O (Input/Output) Signal data and control lines
Test Voltage:	1 KV	0.5 KV
Polarity:	Positive & Negative	
Impulse Wave Shape:	5/50ns	
Burst Duration:	15ms	
Burst Period:	300ms	
Test Duration:	Not less than 1 min	

13.2 Test Setup

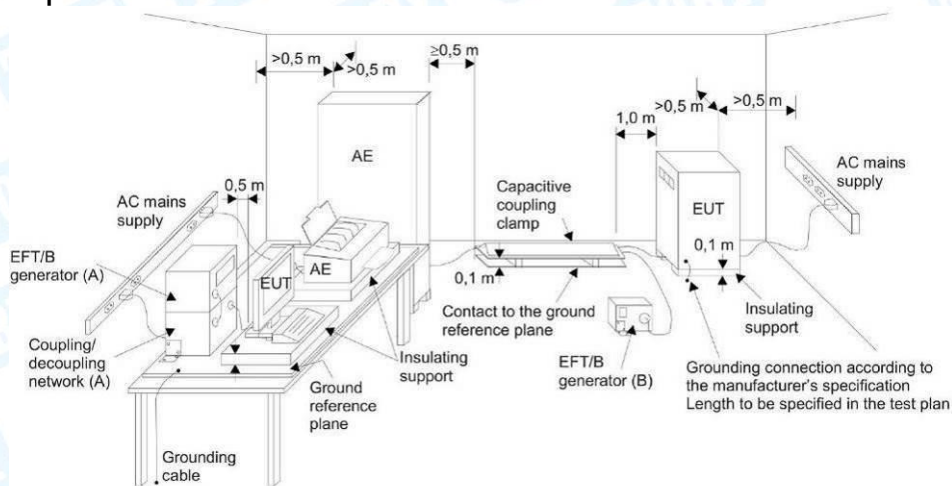

13.3 Test Procedure

The test method shall be in accordance with CENELEC EN 61000-4-4 [4], clauses 7 and 8.

The following requirements and evaluation of test results shall apply:

- the test level for signal ports, wired network ports (excluding xDSL), and control ports shall be 0,5 kV open circuit voltage at a repetition rate of 5 kHz as given in CENELEC EN 61000-4-4 [4], clause 5;
- the test level for xDSL wired network ports shall be 0,5 kV open circuit voltage at a repetition rate of 100 kHz as given in CENELEC EN 61000-4-4 [4], clause 5;
- the test level for DC power input ports shall be 0,5 kV open circuit voltage at a repetition rate of 5 kHz as given CENELEC EN 61000-4-4 [4], clause 5;
- the test level for AC mains power input ports shall be 1 kV open circuit voltage at a repetition rate of 5 kHz as given CENELEC EN 61000-4-4 [4], clause 5.

13.4 Deviation From Test Standard

No deviation

13.5 Test Data

Please refer to the Attachment E.



14 Surge Immunity Test

14.1 Test Standard and Limit

14.1.1 Test Standard

EN 55035:2017+A11:2020
EN 61000-4-5:2014+A1:2017

14.1.2 Test Level

Test Level for Surge Immunity Test

Basic Standard:	EN 61000-4-5
Test Requirement:	Analogue/digital data ports: 1KV (see a)
	DC network power ports: 0.5KV
	AC mains power ports: 1KV(Line-Line), 2KV(Line-earth)
T_r/T_h	1.2/50us, 10/700us
Polarity:	Positive/Negative
Phase Angle:	0/90/180/270
Pulse Repetition Rate:	1 time/min.(maximum)
Number of Tests:	5 positive and 5 negative at selected points

a: Port type: coaxial or shielded. Apply: shield to ground.

14.2 Test Setup

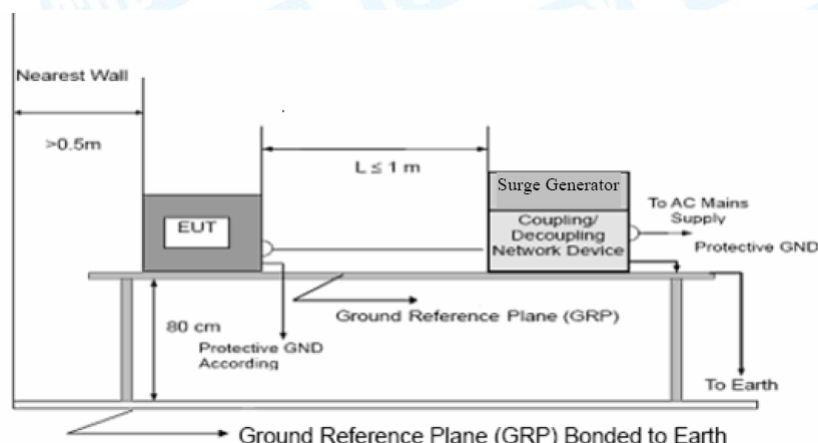

14.3 Test Procedure

- 1) Set the parameters of the CW generator and interference generator as shown in tables 4.2.9.2-1 and 4.2.9.2-2.
- 2) Set the power level of the UE according to tables 4.2.9.2-1 and 4.2.9.2-2 with a $\pm 1\text{ dB}$ tolerance.
- 3) Measure the BER of DCH received from the UE at the SS.

Details of initial conditions for UEs supporting UTRA FDD can be found in ETSI TS 134 121-1 [1], clause 6.7.

14.4 Deviation From Test Standard

No deviation

14.5 Test Data

Please refer to the Attachment F.



15 RF Common Mode

15.1 Test Standard and Limit

15.1.1 Test Standard

EN 55035:2017+A11:2020

EN 61000-4-6:2014

15.1.2 Test Level

Test Level for RF Common Mode

Port	Test Specification
Input AC power port/ Signal Port/ Input DC Port	0.15MHz~10MHz 3V(r.m.s.) (unmodulated)
	10MHz~30MHz 3V to 1V(r.m.s.) (unmodulated)
	30MHz~80MHz 1V(r.m.s.) (unmodulated)
Test Signal	80% AM modulated sine wave, 1KHz
<p>Note: Only applies when the overall cable length between the EUT and another item of active equipment may be greater than 3 m.</p>	

15.2 Test Setup

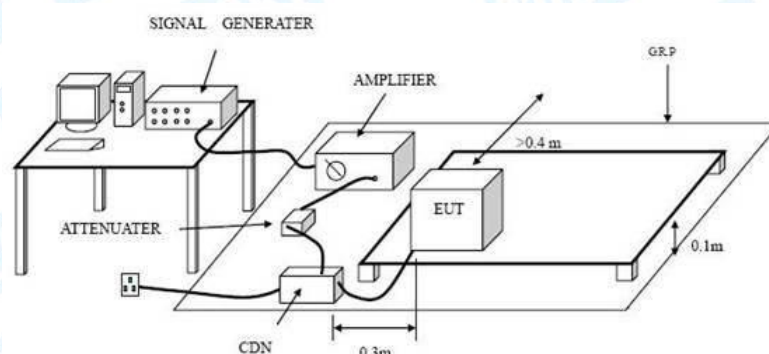

15.3 Test Procedure

The following requirements and evaluation of test results shall apply:

- the test level shall be severity level 2 as given in CENELEC EN 61000-4-6 [6], clause 5 corresponding to 3 V rms unmodulated. The test signal shall then be amplitude modulated to a depth of 80 % by a sinusoidal audio signal of 1 000 Hz. If the wanted signal is modulated at 1 000 Hz, then the test signal of 400 Hz shall be used;
- the test shall be performed over the frequency range 150 kHz to 80 MHz with the exception of an exclusion band for transmitters, and for receivers and duplex transceivers, (see clause 4.3);
- for receivers and transmitters the stepped frequency increments shall be 1 % frequency increment of the momentary frequency in the frequency range 150 kHz to 80 MHz;
- the injection method to be used shall be selected according to the basic standard CENELEC EN 61000-4-6 [6], clause 7;
- responses on receivers or receiver parts of transceivers occurring at discrete frequencies which are narrow band responses (spurious responses), are disregarded from the test (as specified in clause 4); the dwell time of the test



phenomena at each frequency shall not be less than the time necessary for the EUT to be exercised and to be able to respond;

- the frequencies of the immunity test signal selected and used during the test shall be recorded.

15.4 Deviation From Test Standard

No deviation

15.5 Test Data

Please refer to the Attachment G.



16 Power frequency Magnetic Field Immunity Test

16.1 Test Standard and Limit

16.1.1 Test Standard

EN 55035:2017+A11:2020

EN 61000-4-8:2010

16.1.2 Test Level

Level	Field Strength A/m
1	1
2	3
3	10
4	30
5	100
X	Special

16.2 Test Setup

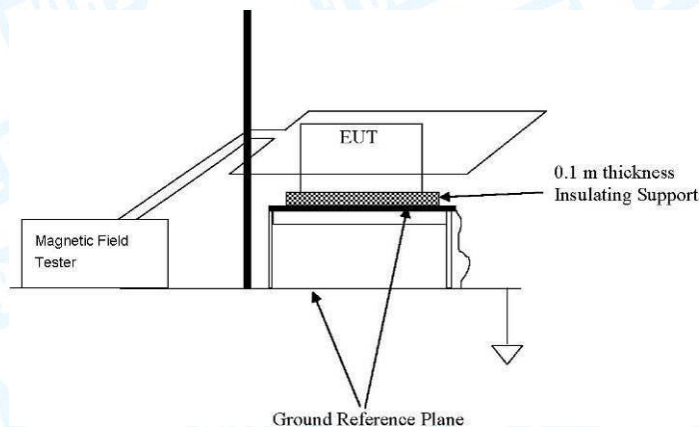

16.3 Test Procedure

The EUT is placed in the middle of a induction coil (1*1m), under which is a 1*1*0.1m (high) table, this small table is also placed on a larger table, 0.8 m above the ground. The X, Y and Z polarization of the induction coil is set on test, so that each side of the EUT is affected by the magnetic field. Also can reach the same aim by change the position of the EUT.

16.4 Deviation From Test Standard

No deviation

16.5 Test Data

N/A.



17 Voltage Dips and Interruptions Immunity Test

17.1 Test Standard and Limit

17.1.1 Test Standard

EN 55035:2017+A11:2020

EN IEC 61000-4-11:2020

17.1.2 Test Level

Test Level for Voltage Dips and Interruptions

Basic Standard:	EN IEC 61000-4-11
Required Performance:	B(For 100%, 0.5 cycle Voltage Dips) C(For 70%, 25 cycles for 50Hz, 30 cycles for 60Hz Voltage Dips) C(For 100%, 250 cycles for 50Hz, 300 cycles for 60Hz Voltage Interruptions)
Test Duration Time:	Minimum three test events in sequence
Interval Between Event:	Minimum ten seconds
Phase Angle:	0°/45°/90°/135°/180°/225°/270°/315°/360°
Test Cycle:	3 times

17.2 Test Setup

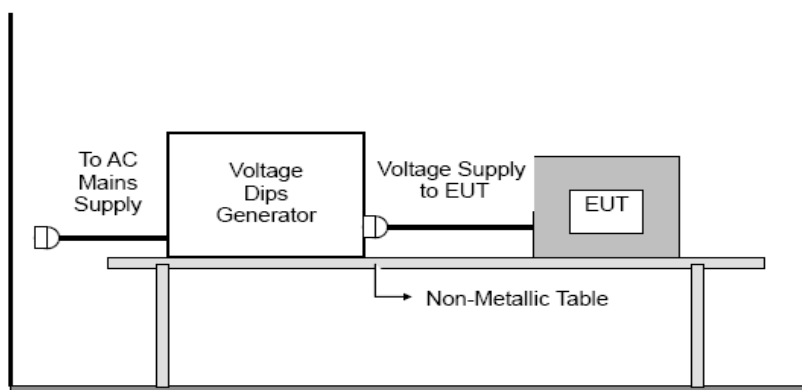

17.3 Test Procedure

The following requirements and evaluation of test results shall apply.

The test method shall be in accordance with CENELEC EN 61000-4-11

The test levels shall be:

For 100%, 0.5 cycle Voltage Dips)

For 70%, 25 cycles for 50Hz, 30 cycles for 60Hz Voltage Dips)

For 100%, 250 cycles for 50Hz, 300 cycles for 60Hz Voltage Interruptions)

17.4 Deviation From Test Standard

No deviation

17.5 Test Data

Please refer to the Attachment H.



18 Photographs--Constructional Details

Photo 1 Appearance of EUT



Photo 2 Appearance of Adapter

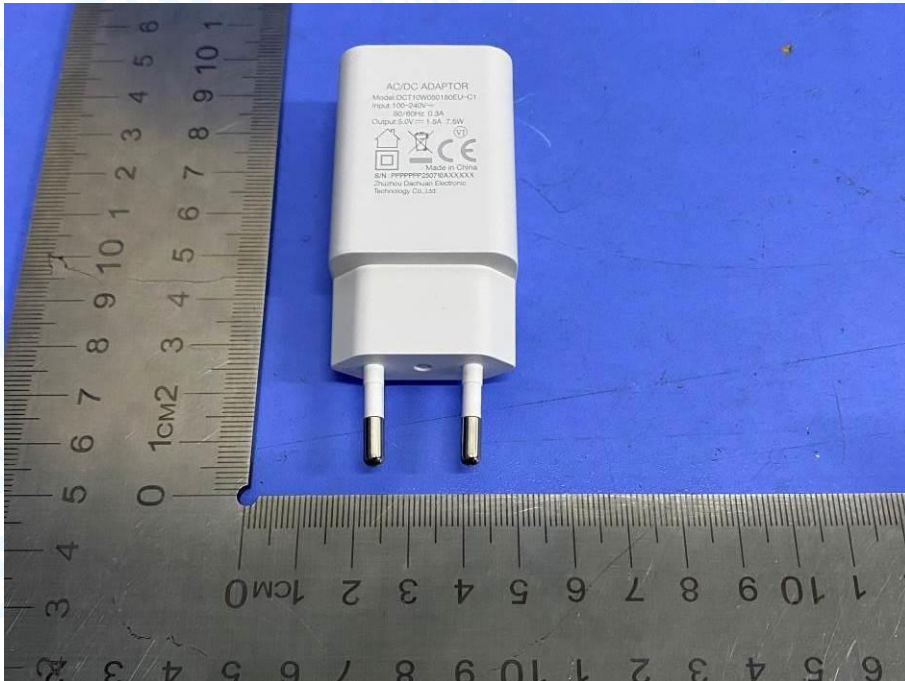

Photo 3 Appearance of EUT

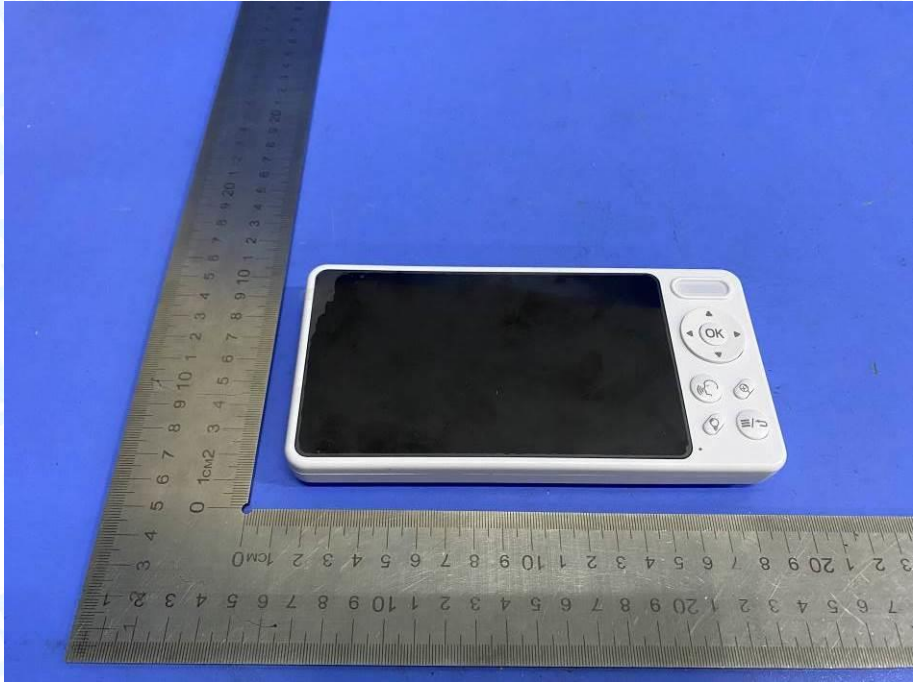

Photo 4 Appearance of EUT

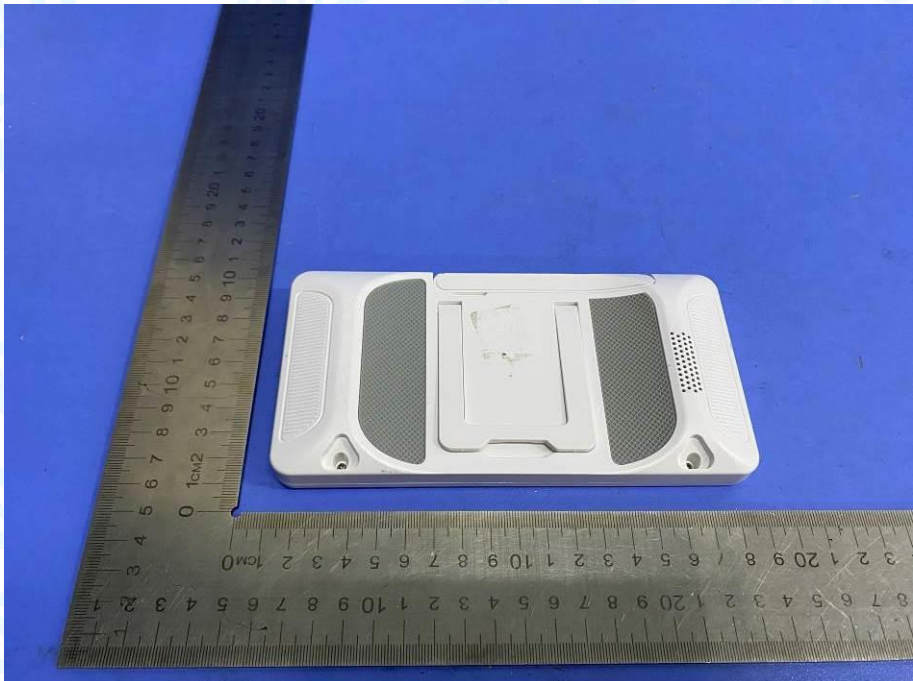

Photo 5 Appearance of EUT



Photo 6 Appearance of EUT

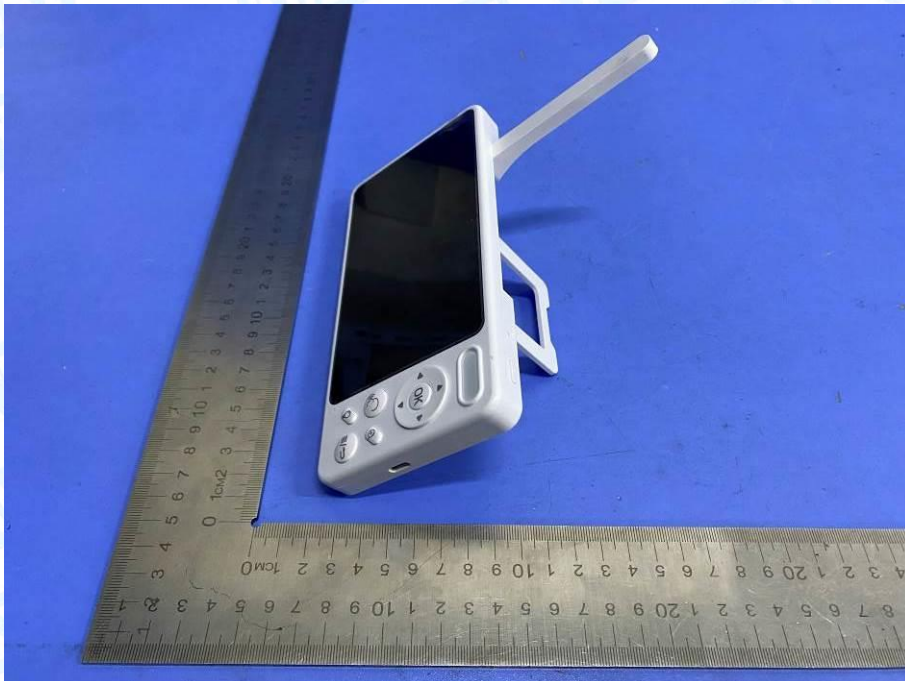

Photo 7 Appearance of EUT

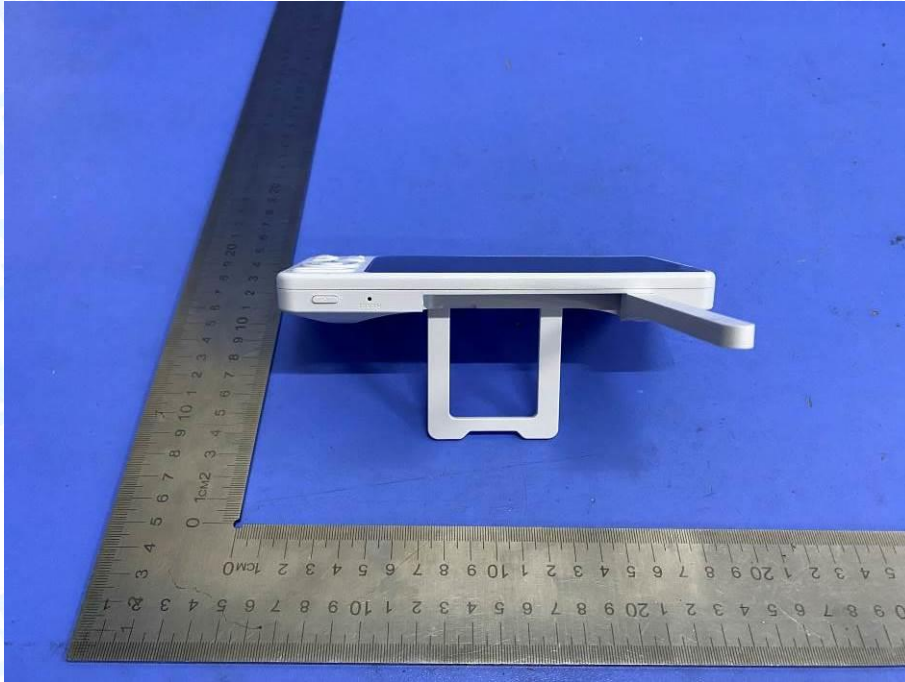

Photo 8 Appearance of EUT

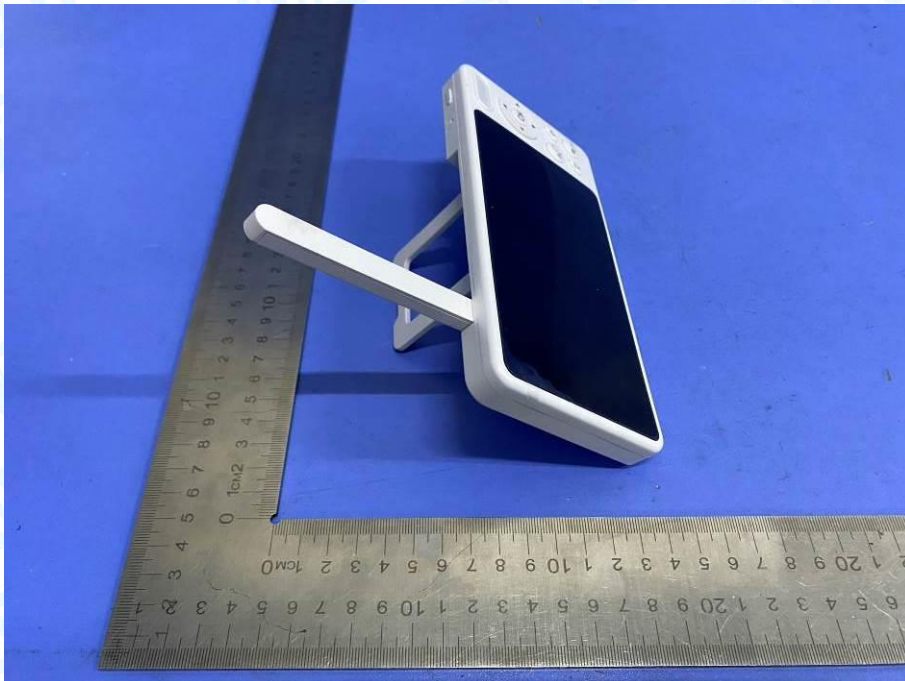

Photo 9 Internal of EUT

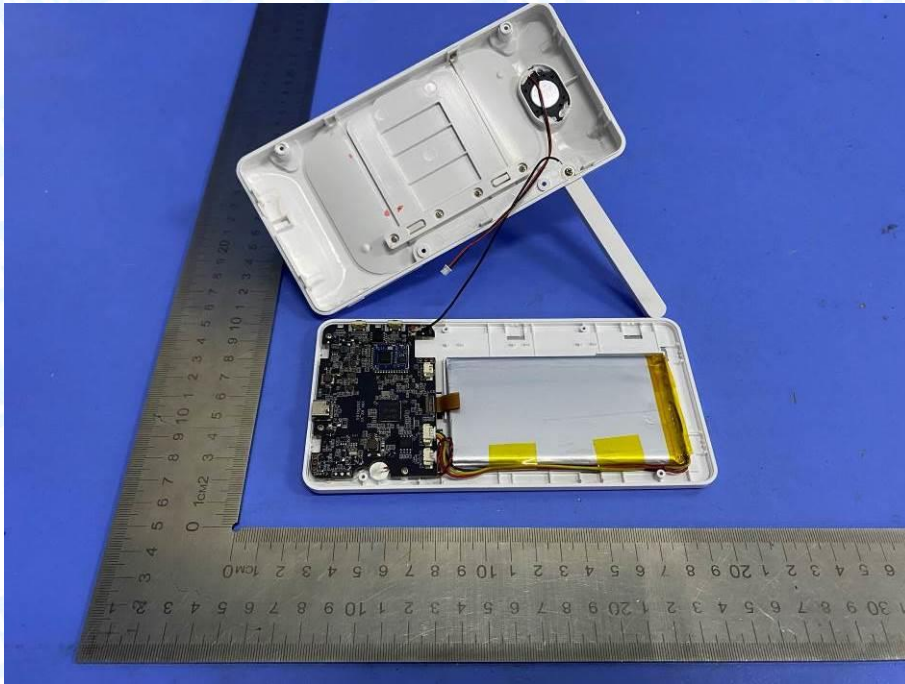

Photo 10 Internal of EUT

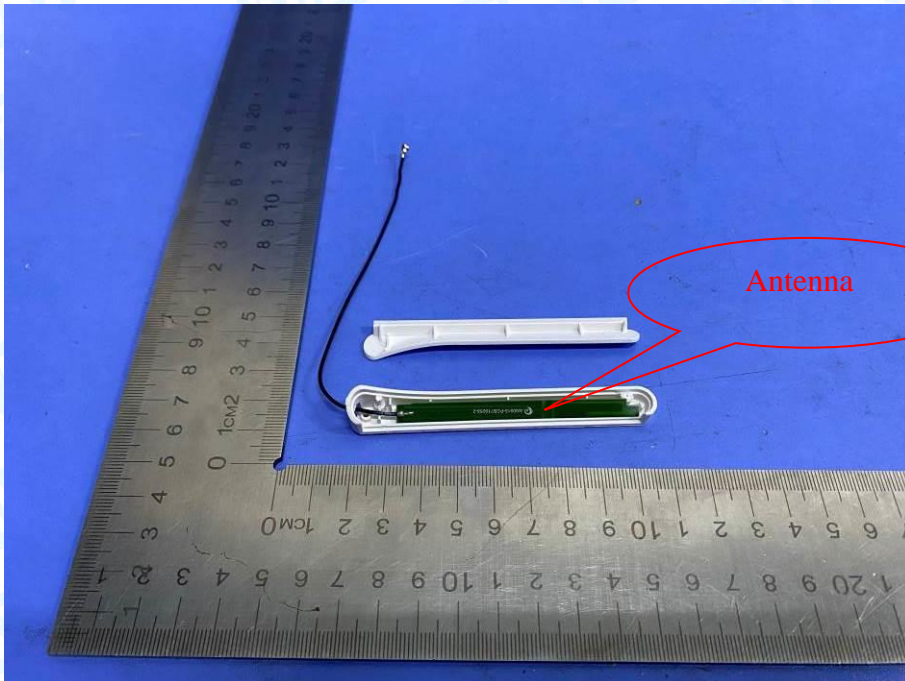

Photo 11 Internal of EUT

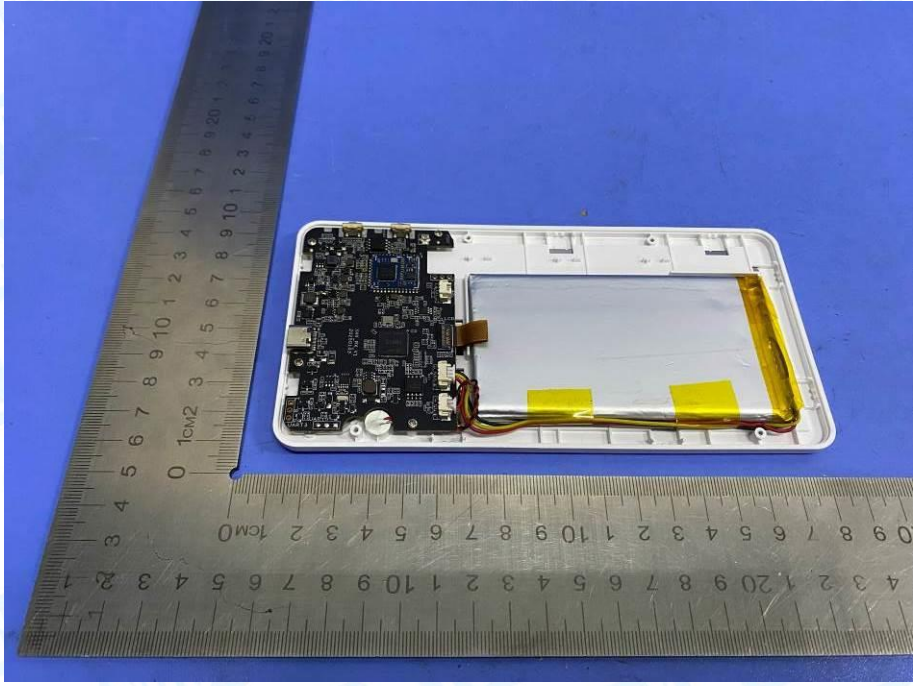

Photo 12 Internal of Battery

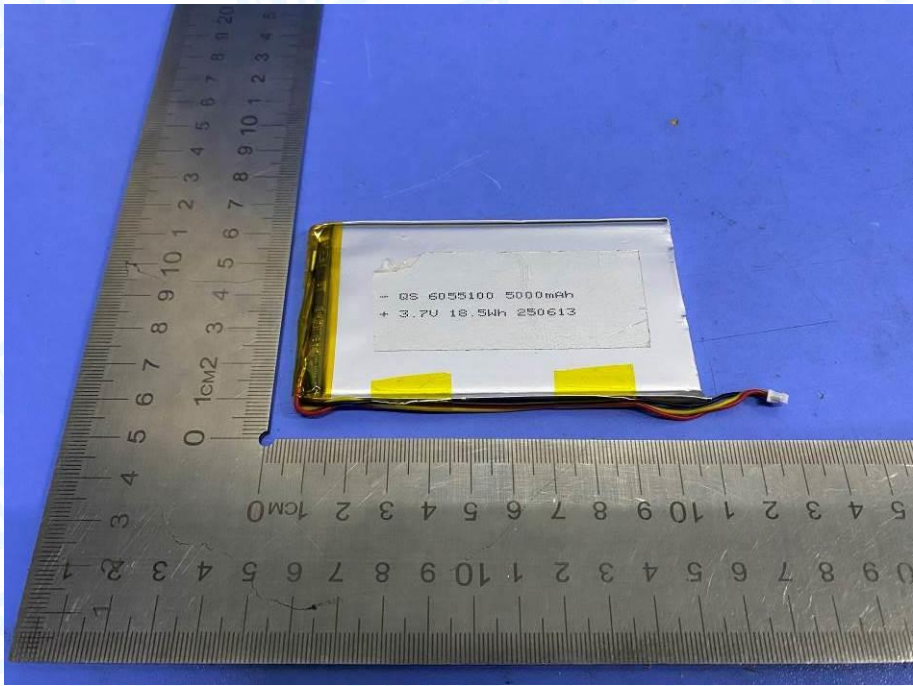

Photo 13 Appearance of PCB

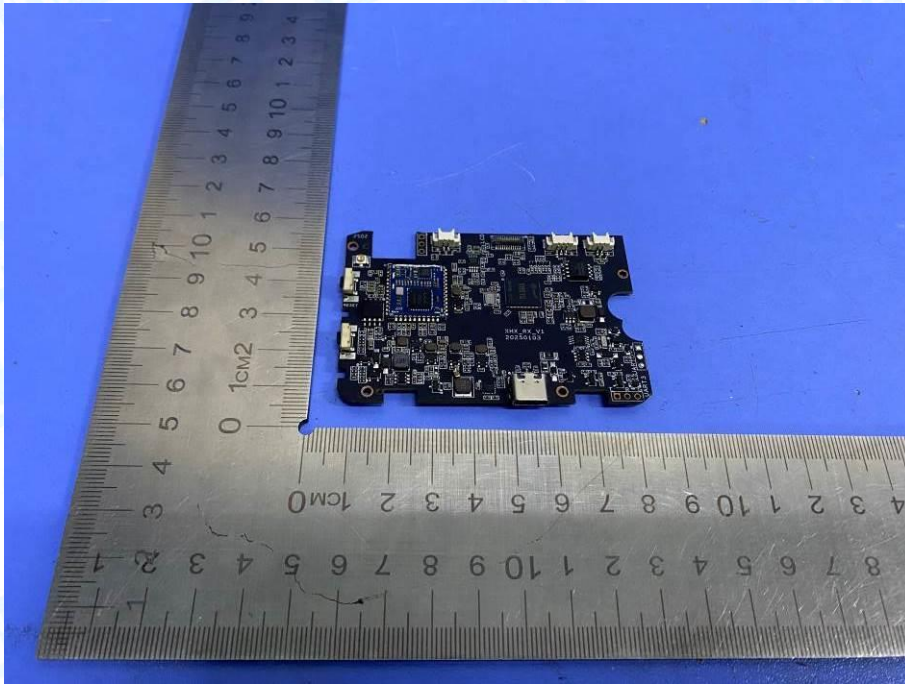
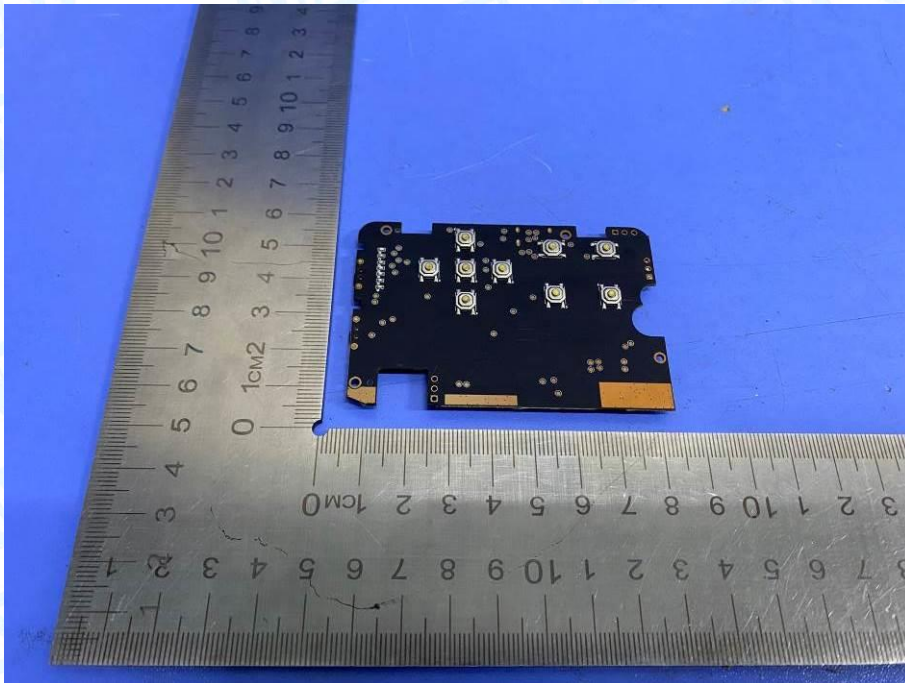
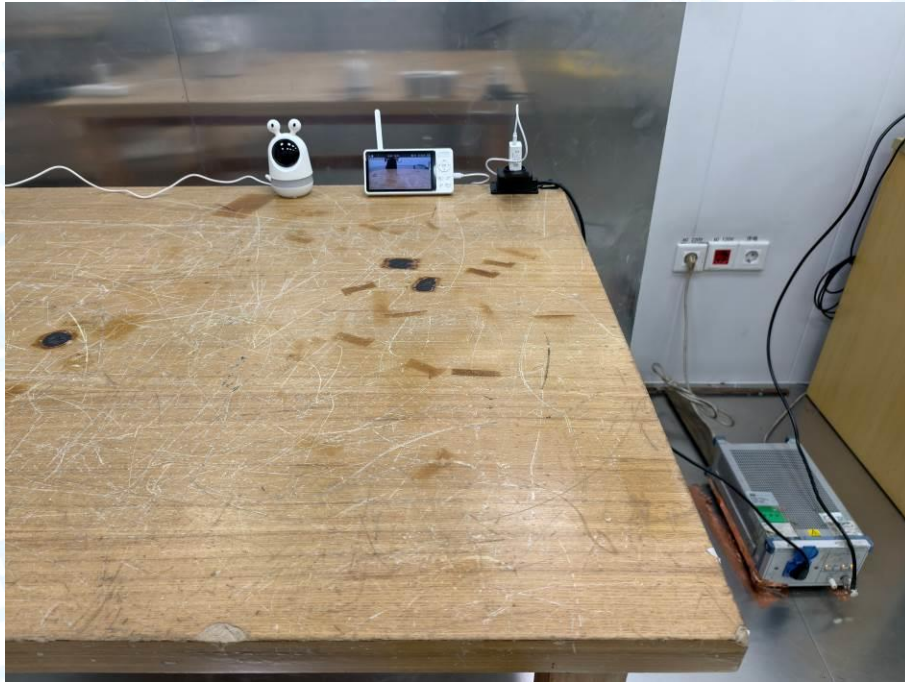

Photo 14 Appearance of PCB



19 Photographs--Test Setup

Conducted Emission Test Setup



Radiated Emission Test Setup-Below 1G

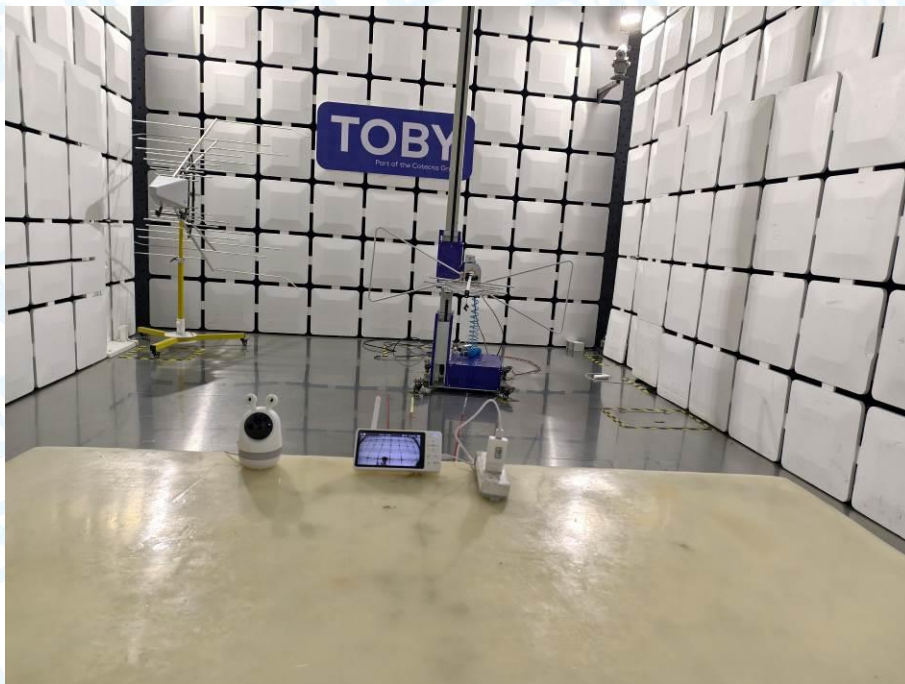

Radiated Emission Test Setup-Above 1G

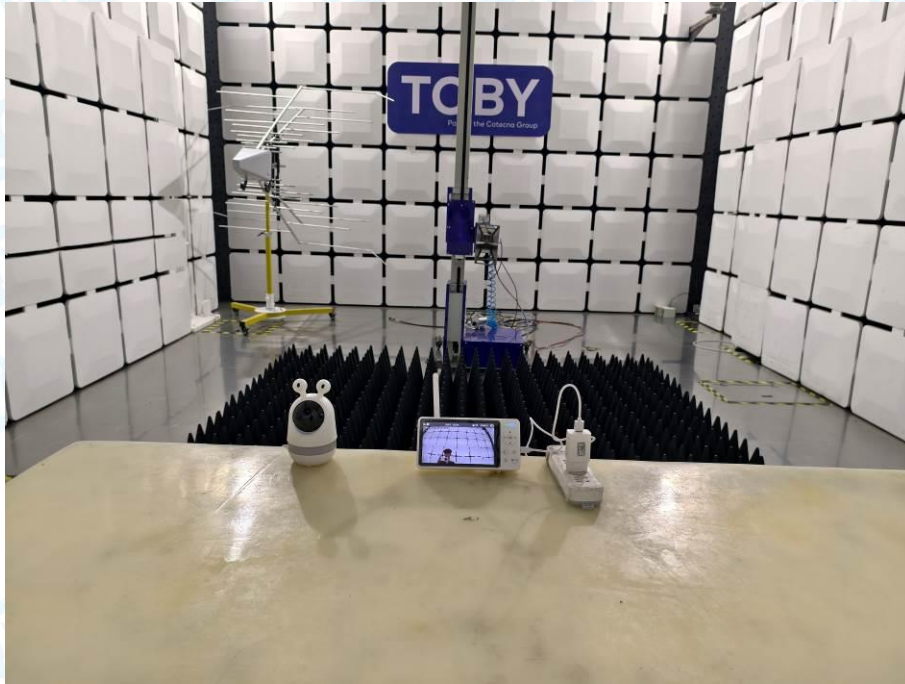

Electrostatic Discharge Test Setup

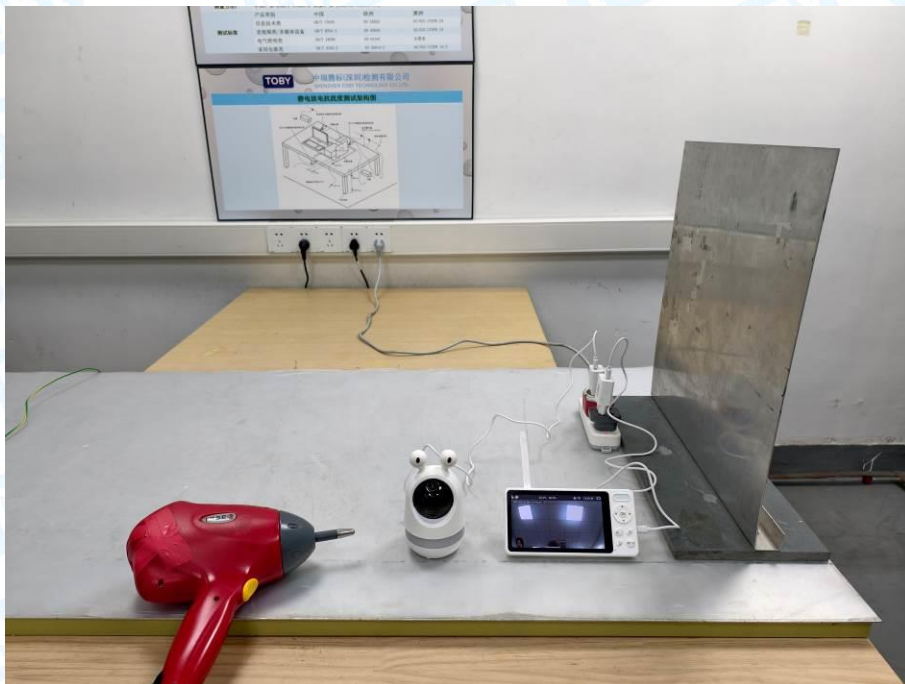

Radiated Immunity Test Setup

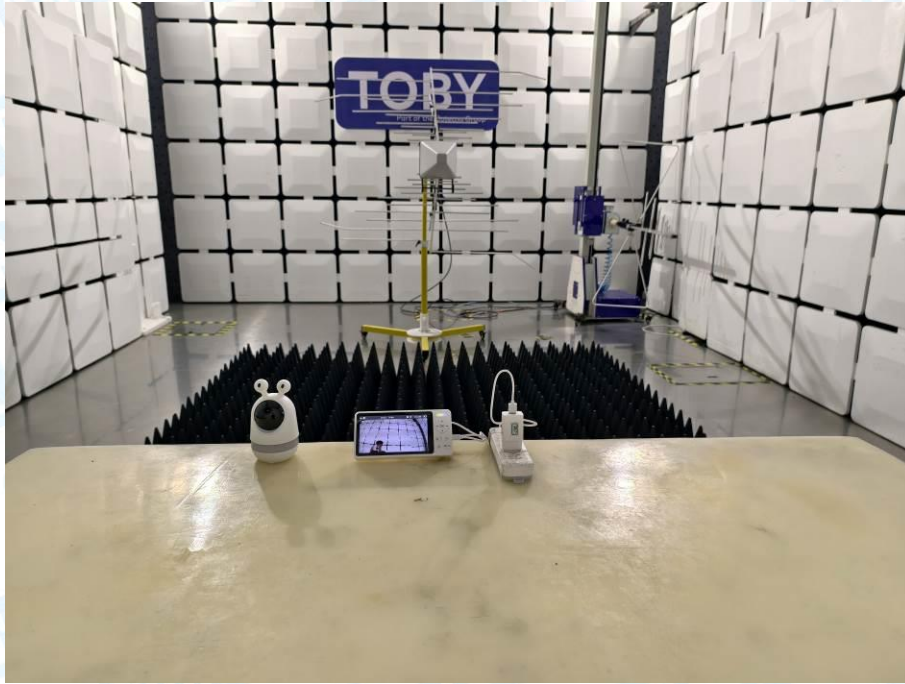

Attachment A--Conducted Emission Data (AC Mains)

Pressure:	1020hPa
Test Voltage:	AC 230V/50Hz
Terminal:	Line
Test Mode:	Mode 1
Remark:	Only showed test data of the worst mode

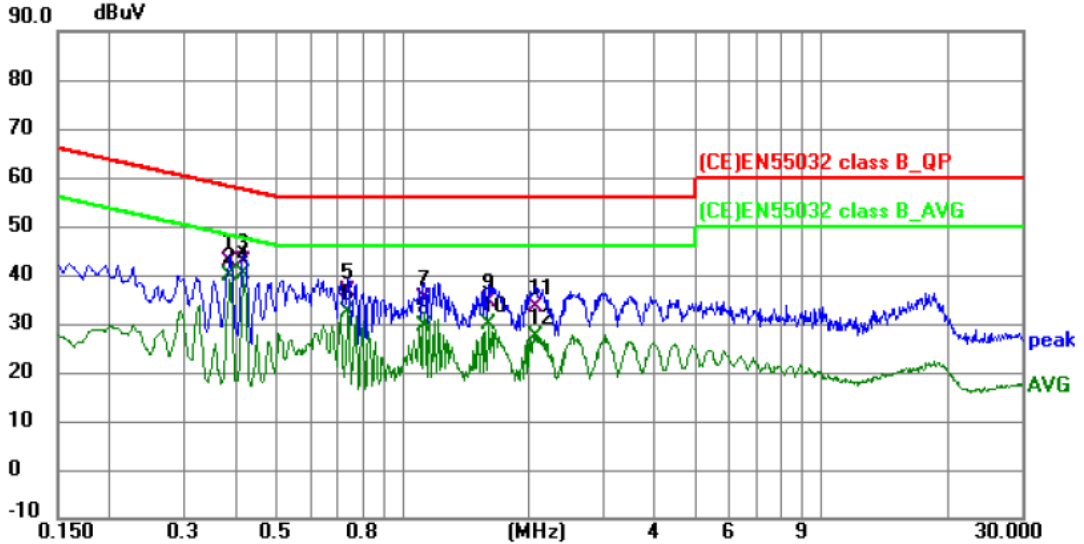

Temperature: 23.5 °C

Humidity: 49 %RH

No.	Mk.	Freq. MHz	Reading Level dBuV	Correct Factor dB	Measure- ment dBuV	Limit dBuV	Over dB	Detector
1		0.384	32.71	9.93	42.64	58.19	-15.55	QP
2		0.384	29.98	9.93	39.91	48.19	-8.28	AVG
3		0.415	32.92	9.92	42.84	57.55	-14.71	QP
4	*	0.415	30.13	9.92	40.05	47.55	-7.50	AVG
5		0.740	26.60	9.90	36.50	56.00	-19.50	QP
6		0.740	22.50	9.90	32.40	46.00	-13.60	AVG
7		1.127	25.18	10.05	35.23	56.00	-20.77	QP
8		1.127	19.36	10.05	29.41	46.00	-16.59	AVG
9		1.599	24.52	10.04	34.56	56.00	-21.44	QP
10		1.599	19.75	10.04	29.79	46.00	-16.21	AVG
11		2.076	23.31	10.05	33.36	56.00	-22.64	QP
12		2.076	17.21	10.05	27.26	46.00	-18.74	AVG

Remark:

1. Corr. Factor (dB) = LISN Factor (dB) + Cable Loss (dB)

2. Margin (dB) = QuasiPeak/Average (dBuV) - Limit (dBuV)



Pressure:	1020hPa
Test Voltage:	AC 230V/50Hz
Terminal:	Neutral
Test Mode:	Mode 1
Remark:	Only showed test data of the worst mode

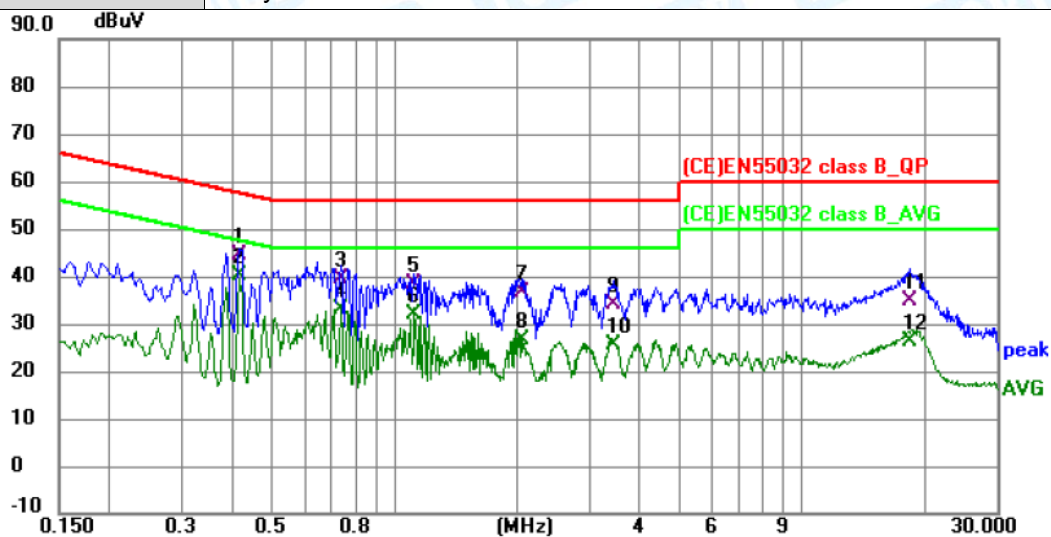

Temperature: 23.5 °C

Humidity: 49 %RH

No.	Mk.	Freq. MHz	Reading Level dBuV	Correct Factor dB	Measure- ment dBuV	Limit dBuV	Over dB	Detector
1		0.415	34.63	9.93	44.56	57.55	-12.99	QP
2	*	0.415	30.09	9.93	40.02	47.55	-7.53	AVG
3		0.740	29.58	9.88	39.46	56.00	-16.54	QP
4		0.740	23.16	9.88	33.04	46.00	-12.96	AVG
5		1.122	28.34	9.89	38.23	56.00	-17.77	QP
6		1.122	21.93	9.89	31.82	46.00	-14.18	AVG
7		2.049	26.53	9.96	36.49	56.00	-19.51	QP
8		2.049	16.80	9.96	26.76	46.00	-19.24	AVG
9		3.462	24.10	10.01	34.11	56.00	-21.89	QP
10		3.462	15.52	10.01	25.53	46.00	-20.47	AVG
11		18.393	24.09	10.90	34.99	60.00	-25.01	QP
12		18.393	15.40	10.90	26.30	50.00	-23.70	AVG

Remark:

1. Corr. Factor (dB) = LISN Factor (dB) + Cable Loss (dB)

2. Margin (dB) = QuasiPeak/Average (dBuV) - Limit (dBuV)



Attachment B--Radiated Emission Test Data

----Below 1GHz

Pressure:	1020hPa
Test Voltage:	AC 230V/50Hz
Ant. Pol.	Horizontal
Test Mode:	Mode 1
Remark:	Only showed test data of the worst mode

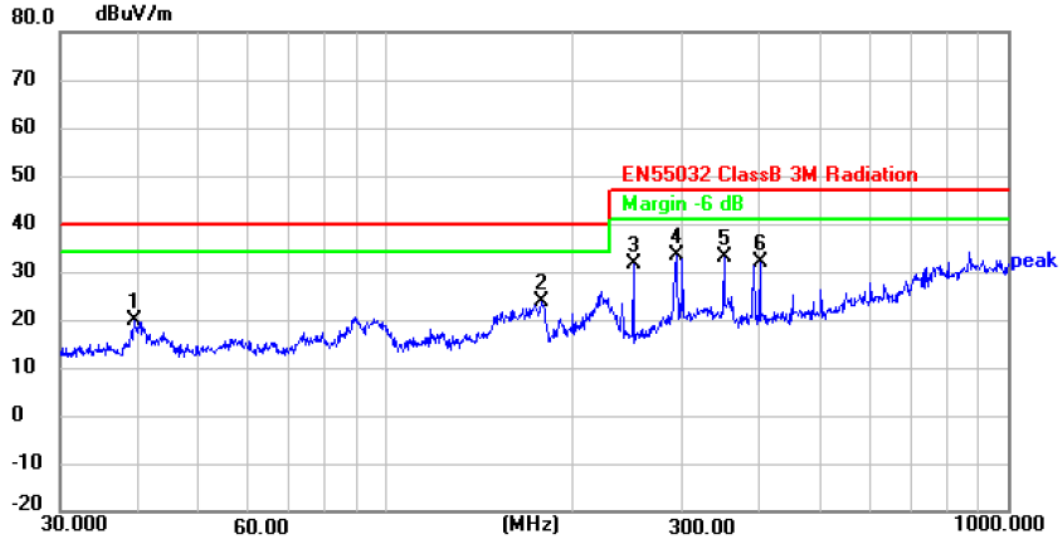

Temperature: 23.8 °C

Humidity: 49 %

No.	Frequency (MHz)	Reading (dBuV)	Factor (dB/m)	Level (dBuV/m)	Limit (dBuV/m)	Margin (dB)	Detector	P/F
1	39.5757	43.35	-23.43	19.92	40.00	-20.08	peak	P
2	178.1327	46.56	-22.97	23.59	40.00	-16.41	peak	P
3	250.3011	55.88	-24.11	31.77	47.00	-15.23	peak	P
4 *	293.0842	54.93	-21.55	33.38	47.00	-13.62	peak	P
5	350.4767	52.73	-19.87	32.86	47.00	-14.14	peak	P
6	400.4318	51.89	-19.95	31.94	47.00	-15.06	peak	P

Remark:

1. Corr. = Antenna Factor (dB/m) + Cable Loss (dB)
2. QuasiPeak (dBµV/m)= Corr. (dB/m)+ Read Level (dBµV)
3. Margin (dB) = QuasiPeak (dBµV/m)-Limit QPK(dBµV/m)



Pressure:	1020hPa
Test Voltage:	AC 230V/50Hz
Ant. Pol.	Vertical
Test Mode:	Mode 1
Remark:	Only showed test data of the worst mode

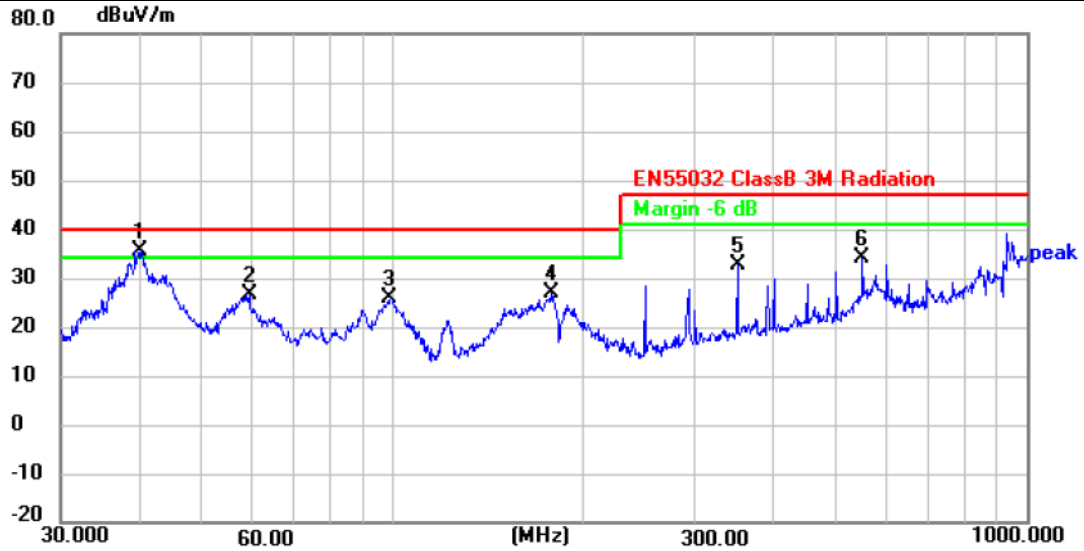

Temperature: 23.8 °C

Humidity: 49 %

No.	Frequency (MHz)	Reading (dBuV)	Factor (dB/m)	Level (dBuV/m)	Limit (dBuV/m)	Margin (dB)	Detector	P/F
1 *	40.2754	59.04	-23.55	35.49	40.00	-4.51	peak	P
2	59.4405	50.65	-24.16	26.49	40.00	-13.51	peak	P
3	99.5279	52.01	-25.98	26.03	40.00	-13.97	peak	P
4	178.7583	50.10	-23.28	26.82	40.00	-13.18	peak	P
5	350.4766	52.51	-19.87	32.64	47.00	-14.36	peak	P
6	550.9480	48.76	-14.54	34.22	47.00	-12.78	peak	P

Remark:

1. Corr. = Antenna Factor (dB/m) + Cable Loss (dB)
2. QuasiPeak (dBμV/m)= Corr. (dB/m)+ Read Level (dBμV)
3. Margin (dB) = QuasiPeak (dBμV/m)-Limit QPK(dBμV/m)



-----Above 1G

Pressure:	1020hPa
Test Voltage:	AC 230V/50Hz
Ant. Pol.	Horizontal
Test Mode:	Mode 1
Remark:	N/A

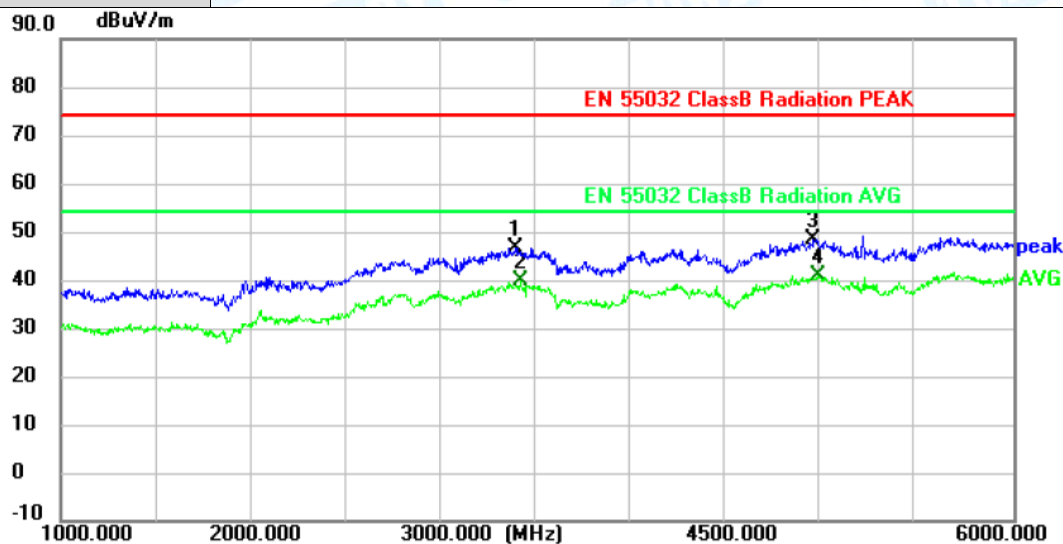

Temperature: 23.8 °C

Humidity: 49 %

No.	Frequency (MHz)	Reading (dBuV)	Factor (dB/m)	Level (dBuV/m)	Limit (dBuV/m)	Margin (dB)	Detector	P/F
1	3385.000	53.92	-7.15	46.77	74.00	-27.23	peak	P
2	3410.000	46.84	-7.19	39.65	54.00	-14.35	AVG	P
3	4950.000	49.44	-1.09	48.35	74.00	-25.65	peak	P
4 *	4980.000	41.98	-1.09	40.89	54.00	-13.11	AVG	P

Remark:

1. Corr. = Antenna Factor (dB/m) + Cable Loss (dB)
2. Peak/AVG (dBuV/m) = Corr. (dB/m) + Read Level (dBuV)
3. Margin (dB) = Peak/AVG (dBuV/m) - Limit PK/AVG (dBuV/m)



Pressure:	1020hPa
Test Voltage:	AC 230V/50Hz
Ant. Pol.	Vertical
Test Mode:	Mode 1
Remark:	N/A

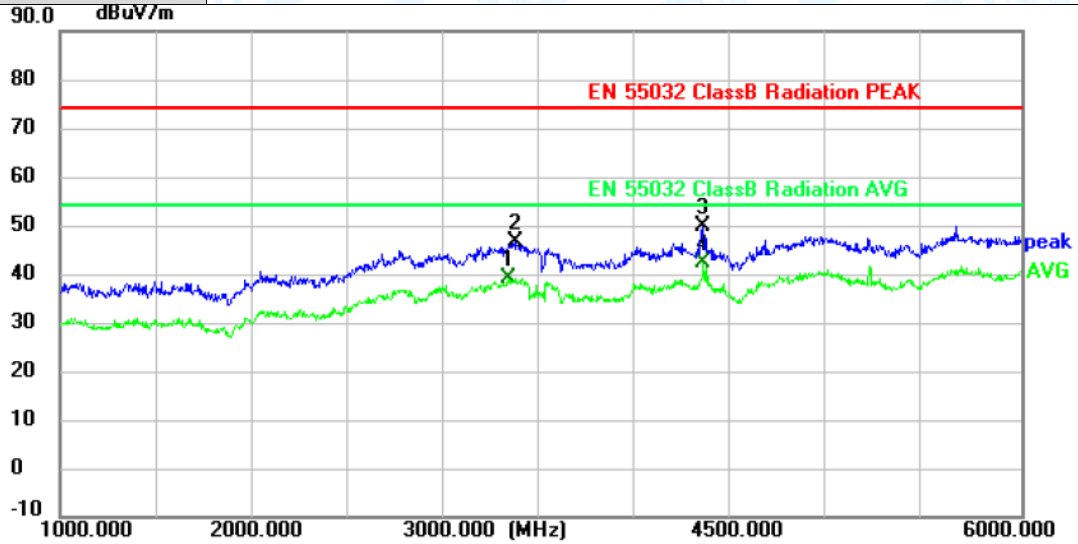

Temperature: 23.8 °C

Humidity: 49 %

No.	Frequency (MHz)	Reading (dBuV)	Factor (dB/m)	Level (dBuV/m)	Limit (dBuV/m)	Margin (dB)	Detector	P/F
1	3330.000	46.39	-7.30	39.09	54.00	-14.91	AVG	P
2	3365.000	53.66	-7.04	46.62	74.00	-27.38	peak	P
3	4340.000	52.37	-2.43	49.94	74.00	-24.06	peak	P
4 *	4345.000	44.56	-2.19	42.37	54.00	-11.63	AVG	P

Remark:

1. Corr. = Antenna Factor (dB/m) + Cable Loss (dB)
2. Peak/AVG (dBuV/m) = Corr. (dB/m) + Read Level (dBuV)
3. Margin (dB) = Peak/AVG (dBuV/m) - Limit PK/AVG (dBuV/m)



Attachment C--Electrostatic Discharge Test Data

Temperature:	24.2°C								Humidity:	48%								
Pressure(hpa):	1020																	
Power supply:	AC 230V/50Hz								Test Mode:	Mode 1								
Location	Test Level(Kv) and Result														Criteria	Result		
	Air Discharge							Contact Discharge										
	2		4		8		15	2		4		6		8				
	+	-	+	-	+	-	+	-	+	-	+	-	+	-			+	-
A1	A	A	A	A	A	A	/	/	/	/	/	/	/	/	/	/	B	PASS
A2	A	A	A	A	A	A	/	/	/	/	/	/	/	/	/	/	B	PASS
A3	A	A	A	A	A	A	/	/	/	/	/	/	/	/	/	/	B	PASS
A4	A	A	A	A	A	A	/	/	/	/	/	/	/	/	/	/	B	PASS
A5	A	A	A	A	A	A	/	/	/	/	/	/	/	/	/	/	B	PASS
A6	A	A	A	A	A	A	/	/	/	/	/	/	/	/	/	/	B	PASS
Test Level(kV) and Result																		
Location	HCP								VCP								Criteria	Result
	2		4		6		8		2		4		6		8			
	+	-	+	-	+	-	+	-	+	-	+	-	+	-	+	-		
Front	A	A	A	A	/	/	/	/	A	A	A	A	/	/	/	/	B	PASS
Back	A	A	A	A	/	/	/	/	A	A	A	A	/	/	/	/	B	PASS
Left	A	A	A	A	/	/	/	/	A	A	A	A	/	/	/	/	B	PASS
Right	A	A	A	A	/	/	/	/	A	A	A	A	/	/	/	/	B	PASS
Note: "/" Representative the test not applicable																		
Criteria A: There was no change operated with initial operating during the test.																		
Criteria B: The EUT function loss during the test, but self-recoverable after the test.																		
Criteria C: The system shut down during the test.																		



Test Location Photos

A1		A3
A2		A4
		A5
A6		

Note:

- 1) Criteria A: There was no change operated with initial operating during the test.
- 2) Criteria B: The EUT function loss during the test, but self-recoverable after the test.
- 3) Criteria C: The system shut down during the test.



Attachment D--RF Field Strength Susceptibility Test Data

Temperature : 24.5°C		Humidity : 46%							
Pressure(hpa) : 1020									
Power supply : AC 230V/50Hz		Test Mode : Mode 1							
Required Performance Criteria: A									
Modulation: AM 80% , Field strength: 3V/m, Pulse: 1 kHz.									
Antenna Polarity	Actual Performance Criteria				Result				
	Frequency Range : 80~1000MHz								
	EUT Position								
	Front	Right	Rear	Left					
H	A	A	A	A	PASS				
V	A	A	A	A	PASS				
EUT Position	Frequency								Result
	1800MHz		2600MHz		3500MHz		5000MHz		
	Antenna Polarity								
	H	V	H	V	H	V	H	V	
Front	A	A	A	A	A	A	A	A	PASS
Right	A	A	A	A	A	A	A	A	PASS
Rear	A	A	A	A	A	A	A	A	PASS
Left	A	A	A	A	A	A	A	A	PASS
Remark:									
1) Criteria A: There was no change operated with initial operating during the test.									
2) Criteria B: The EUT function loss during the test, but self-recoverable after the test.									
3) Criteria C: The system shut down during the test.									



Attachment E--Electrical Fast Transient/Burst Test Data

Temperature : 24.2°C		Humidity : 48%				
Pressure(hpa) : 1020						
Power supply : AC 230V/50Hz			Test Mode : Mode 1			
Required Performance Criteria: B						
Line	Voltage (kV)	Required Performance Criteria		Actual Performance Criteria		Result
		(+)	(-)	(+)	(-)	
L	1.0	B	B	A	A	PASS
N	1.0	B	B	A	A	PASS
L-N	1.0	B	B	A	A	PASS
PE	1.0	B	B	/	/	/
L-PE	1.0	B	B	/	/	/
N-PE	1.0	B	B	/	/	/
L-N-PE	1.0	B	B	/	/	/
RJ45 Port	0.5	B	B	/	/	/
Remark:						
1) Criteria A: There was no change operated with initial operating during the test. 2) Criteria B: The EUT function loss during the test, but self-recoverable after the test. 3) Criteria C: The system shut down during the test.						



Attachment F--Surge Immunity Test Data

Temperature : 24.2°C

Humidity : 48%

Pressure(hpa) : 1020

Power supply : AC 230V/50Hz

Test Mode : Mode 1

Required Performance Criteria: B

 T_r/T_h : 1.2/50us for AC Power Port, T_r/T_h : 10/700us for data ports

Injected Line	Voltage (kV)	Pulse number	Phase	Actual Performance Criteria		Result	
				(+)	(-)	(+)	(-)
L-N	1.0	10	0°	A	A	PASS	PASS
		10	90°	A	A	PASS	PASS
		10	180°	A	A	PASS	PASS
		10	270°	A	A	PASS	PASS
L-PE	2.0	/	0°	/	/	/	/
		/	90°	/	/	/	/
		/	180°	/	/	/	/
		/	270°	/	/	/	/
N-PE	2.0	/	0°	/	/	/	/
		/	90°	/	/	/	/
		/	180°	/	/	/	/
		/	270°	/	/	/	/
RJ45 Port	1.0	10	+/-	/	/	/	/

Remark:

- 1) Criteria A: There was no change operated with initial operating during the test.
- 2) Criteria B: The EUT function loss during the test, but self-recoverable after the test.
- 3) Criteria C: The system shut down during the test.



Attachment G--Conducted Immunity Test Data

Temperature	: 24.2°C	Humidity	: 48%
Pressure(hpa)	: 1020		
Power supply	: AC 230V/50Hz	Test Mode	: Mode 1

Required Performance Criteria: A

Frequency Range (MHz)	Injected Position	Voltage Level (e.m.f.)	Required Performance Criteria	Actual Performance Criteria	Result
0.15 ~ 10	AC Mains	3V(rms), AM 80% Modulated with 1 kHz	A	A	PASS
10 ~ 30		3V to 1V(rms), AM 80% Modulated with 1 kHz	A	A	PASS
30 ~ 80		1V(rms), AM 80% Modulated with 1 kHz	A	A	PASS
0.15 ~ 10	RJ45 Port	3V(rms), AM 80% Modulated with 1 kHz	A	/	/
10 ~ 30		3V to 1V(rms), AM 80% Modulated with 1 kHz	A	/	/
30 ~ 80		1V(rms), AM 80% Modulated with 1 kHz	A	/	/

Remark:

- 1) Criteria A: There was no change operated with initial operating during the test.
- 2) Criteria B: The EUT function loss during the test, but self-recoverable after the test.
- 3) Criteria C: The system shut down during the test.



Attachment H--Voltage Dips and Interruptions Test Data

Temperature : 24.2°C		Humidity : 48%			
Pressure(hpa) : 1020					
Power supply : AC 230V/50Hz		Test Mode : Mode 1			
Criterion: B&C					
Test Level % UT	Voltage Dips & Short Interruptions % UT	Duration (in period)	Phase Angle	Required Performance Criteria	Result
0	100	250P	0°	C	Pass
70	30	25P	0°	C	Pass
0	100	0.5P	0°	B	Pass
<p>Remark: U_r is the rated voltage for the equipment.</p> <ol style="list-style-type: none"> 1) Criteria A: There was no change operated with initial operating during the test. 2) Criteria B: The EUT function loss during the test, but self-recoverable after the test. 3) Criteria C: The system shut down during the test. 					

-----END OF THE REPORT-----

